



DMH Digital MEMS Inclinometer

Features

- Single-Axis and Dual-Axis Available
- Resolution <0.001°
- Zero Temperature Coefficient: $\pm 0.006^\circ / ^\circ\text{C}$
- Up to $\pm 90^\circ$ Angular Range
- -40° to $+85^\circ\text{C}$ Temperature Range
- 1m cable whip included



Application

- Antenna Deflection Measurement
- Radar & Vehicle Platform Positioning
- Drill Rig Alignment
- Offshore Platform Pitch & Roll
- Industrial Measurement & Control
- Railway Track Alignment & Maintenance

Introduction

The DMH model is a high precision MEMS inclinometer. Units are available with RS232, RS422, RS485 and UART TTL options. All DMH series inclinometers are rated IP67 for waterproofing up to 1m. Custom ranges and output types are also available on request.

Performance specifications

Static/dynamic

| | | | | |
|--|-------------|-------------|-------------|-------------|
| * Angular Range, ° | ± 10 | ± 15 | ± 30 | ± 60 |
| Resolution, ° | 0.001 | 0.001 | 0.001 | 0.001 |
| Hysteresis, ° | 0.005 | 0.007 | 0.008 | 0.01 |
| Zero Tolerance (°) | 0.01 | 0.01 | 0.01 | 0.01 |
| Zero Temperature Coefficient, °/°C | ± 0.006 | ± 0.006 | ± 0.006 | ± 0.006 |
| Scale Factor Tolerance (%) | 0.7 | 1.1 | 1.4 | 2.8 |
| Scale Factor Temperature Coefficient, ppm/°C | ≤ 200 | ≤ 200 | ≤ 200 | ≤ 200 |
| Warm Up, s | 0.5 | 0.5 | 0.5 | 0.5 |
| Time Constant, s | 0.05 | 0.05 | 0.05 | 0.05 |

Electrical and environmental

| | |
|-------------------------------|--|
| Output rate | 5Hz, 15Hz, 35Hz, 50Hz |
| Output Type | RS232, RS422, RS485, UART TTL |
| Electromagnetic Compatibility | EN61000 and GBT17626 |
| Impact Resistance | 100g@11ms, 3 Times/Axis (1/2 sinusoid) |
| Vibration Resistance | 10grms, 10~1000 Hz |
| Temperature Rating, Operation | -40 to $+85^\circ\text{C}$ |
| Temperature Rating, Storage | -55 to $+100^\circ\text{C}$ |
| Seal | IP67 |
| Enclosure | Anodized Aluminum |
| Cables | 1m Cable (standard) |
| Weight | 150g (without cable) |
| Power Requirements | 9-36 VDC @ 60mA |

Notes

* - Custom ranges available, please see model number structure below.

Specifications subject to change without notice on account of continued product development

Outline Diagram

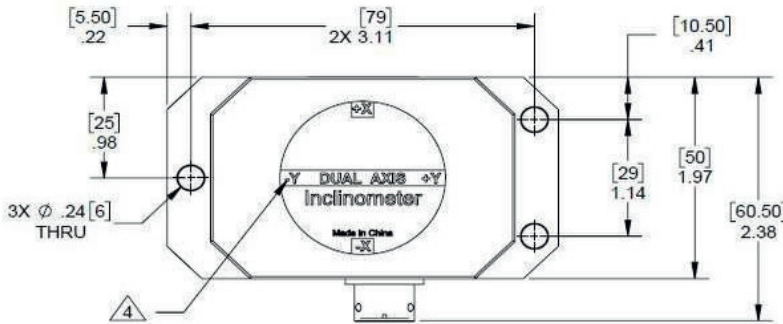

Dimensions in inches [mm]

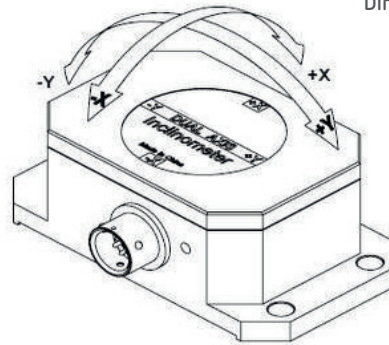
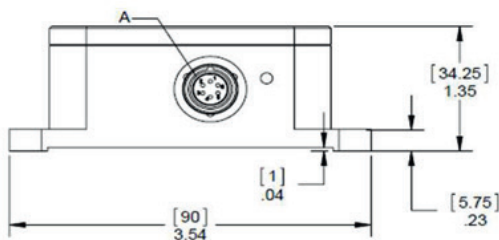

Pin Out



| Pin | Function |
|-----|------------------------|
| 1 | +VDC 9V-36V |
| 2 | RS232 (Rx), RS485 (D+) |
| 3 | RS232 (Tx), RS485 (D-) |
| 4 | Ground |
| 5 | Factory Use Only |

Consult Factory for RS422

Ordering information

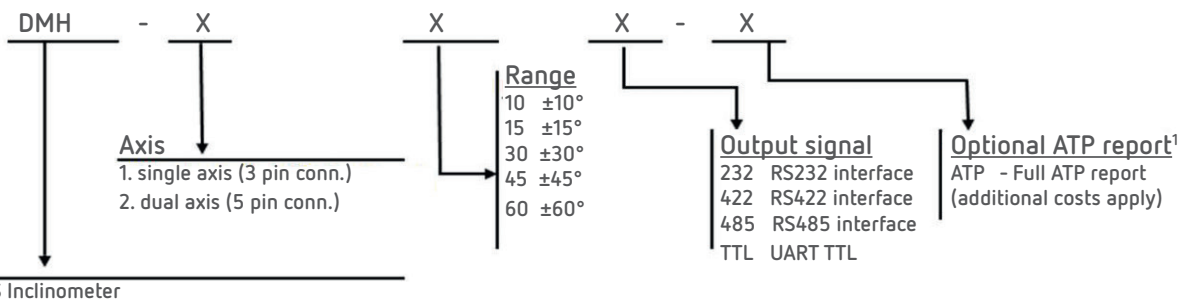

Example:

DMH - 2 - 15 - 232 - ATP

AMH Dual axis, +/- 15 degrees, RS232 interface, Full ATP report

Note

1. "ATP" must be added to the end of the part number for a full ATP report. An additional cost will apply.

ATP report includes: Scale factor, Axis misalignment, Bias, Linearity, Input current

■ Part numbers

| | Single axis | | Dual axis | |
|----------------------|--------------|---------------|--------------|---------------|
| | Model # | Part # | Model # | Part # |
| RS232 Interface | DMH-1-10-232 | 02550319-0111 | DMH-2-10-232 | 02550319-0211 |
| | DMH-1-15-232 | 02550319-0121 | DMH-2-15-232 | 02550319-0221 |
| | DMH-1-30-232 | 02550319-0131 | DMH-2-30-232 | 02550319-0231 |
| | DMH-1-45-232 | 02550319-0141 | DMH-2-45-232 | 02550319-0241 |
| | DMH-1-60-232 | 02550319-0151 | DMH-2-60-232 | 02550319-0251 |
| RS422 Interface | DMH-1-10-422 | 02550319-0112 | DMH-2-10-422 | 02550319-0212 |
| | DMH-1-15-422 | 02550319-0122 | DMH-2-15-422 | 02550319-0222 |
| | DMH-1-30-422 | 02550319-0132 | DMH-2-30-422 | 02550319-0232 |
| | DMH-1-45-422 | 02550319-0142 | DMH-2-45-422 | 02550319-0242 |
| | DMH-1-60-422 | 02550319-0152 | DMH-2-60-422 | 02550319-0252 |
| RS485 Interface | DMH-1-10-485 | 02550319-0113 | DMH-2-10-485 | 02550319-0213 |
| | DMH-1-15-485 | 02550319-0123 | DMH-2-15-485 | 02550319-0223 |
| | DMH-1-30-485 | 02550319-0133 | DMH-2-30-485 | 02550319-0233 |
| | DMH-1-45-485 | 02550319-0143 | DMH-2-45-485 | 02550319-0243 |
| | DMH-1-60-485 | 02550319-0153 | DMH-2-60-485 | 02550319-0253 |
| UARTTTL Interface | DMH-1-10-TTL | 02550319-0114 | DMH-2-10-TTL | 02550319-0214 |
| | DMH-1-15-TTL | 02550319-0124 | DMH-2-15-TTL | 02550319-0224 |
| | DMH-1-30-TTL | 02550319-0134 | DMH-2-30-TTL | 02550319-0234 |
| | DMH-1-45-TTL | 02550319-0144 | DMH-2-45-TTL | 02550319-0244 |
| | DMH-1-60-TTL | 02550319-0154 | DMH-2-60-TTL | 02550319-0254 |

Note

If ATP report is required, please add "-ATP" to model & part numbers. Additional charges will apply