



Scanivalve

MPS42xx Series & Accessories

Digital Miniature Pressure Scanner



Your expert partner in sensors & controls

althensensors.com

ALTHEN
SENSORS & CONTROLS

ABOUT ALTHEN SENSORS & CONTROLS

Althen Sensors & Controls stands for pioneering measurement and sensor solutions. We accept every measurement challenge. We are constantly looking for innovation and are only satisfied when we have found the perfect solution for your measurement task. We develop customer-specific solutions in our in-house production facilities. Althen is partner to many recognized universities and leading organizations. We find ourselves in an intensive knowledge transfer, developing future technologies. Althen is one of the first companies in its branch with a certification by the German technical inspection association in Hessen (TÜV PROFICERT) in accordance with DIN EN ISO 9001:2015.

OUR SERVICE FOR YOU

Are you facing a metrological challenge or do you need a suitable spare part for your application? Our specialists will advise you - in detail and professionally. We keep an eye on your costs and develop customer-specific special solutions if required. Benefit from our many years of experience in the field of measurement technology and sensor technology:



High-quality Production



Measurement and Rental



Special Custom Calibration



Training & Consulting



CONTENTS

MPS4264 Ethernet Miniature Pressure Scanner	4-7
MPS4264EPx Miniature Pressure Scanner Electric Valve	8-9
ES4000 Miniature Ethernet Switch	10
MPS4264TCU Thermal Control Unit	11-13
MPS4232 Miniature Pressure Scanner.....	14-17

APPLICATION / ACCESSORIES

-MPS4264- ETHERNET MINIATURE PRESSURE SCANNER	18
-MPS CAL/REF HEADER KIT	19
-MPS PX INPUT HEADER KIT	19
-MPS PLUMBING DUMMY	19
-POWER CABLE OPTIONS	20
-ETHERNET CABLE OPTIONS	20
-POWER SUPPLY - 5 PORT	21
-Power Supply	21
-MPS Blanking Cover	21
-MPSTCU Breakout Box	21



bar

MPS4264

Miniature Pressure Scanner

FEATURES

- Integral processor for direct Ethernet connection
- New valve design provides „isolate-purge“
- Dynamic zero correction for unmatched sensor stability
- Standard or „Normal Px“ valve control
- IEEE1588-2008v2 PTP compatible
- Up to 2,500 samples/channel/second*
- Simple LabVIEW® integration
- Removable input headers
- Wide operating voltage (9-36Vdc)
- Integral web server

GENERAL DESCRIPTION

The MPS4264 miniature pressure scanner represents the forefront of pressure measurement technology. It has been designed from the ground up with size, accuracy and functionality in mind. It boasts 64 pressure channels, small footprint, TCP/IP Ethernet connectivity, and a wealth of other innovative features.

The MPS4264 is designed around a core sensor pack that uses a custom packaged, ultra-stable sensor. Scani-valve engineers evaluated known causes of non-repeatability in piezoresistive pressure transducers. Designing a double isolation method of bonding the sensors to the base substrates (patented) minimizes the mechanical influences of assembly and thermal expansion. This process dramatically improves the stability and the resulting accuracy of the sensors.

Scani-valve engineers also developed a proprietary means of maximizing sensor stability for span and offset. This technique of “Dynamic Zero Correction” greatly improved the sensor’s stability over time and temperature (patented). The increase in overall sensor stability reduces the need for zero offset and span calibrations, resulting in significantly reduced test interruptions and down time. A brand new valve has been designed that fully isolates the sensors from purge pressure and provides long term,

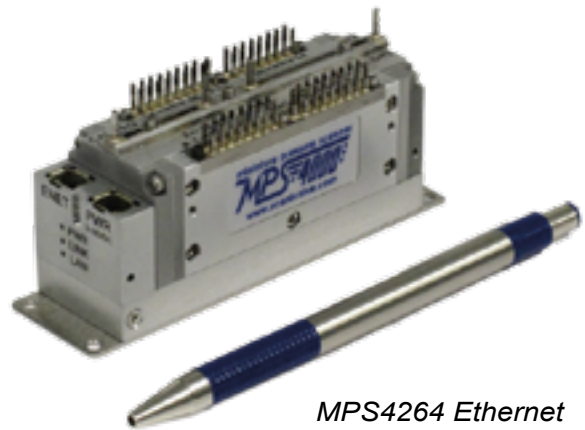

*MPS4264 Ethernet
Pressure Scanner*

maintenance free operation. Not only is the valve design an improvement over legacy products, but two different valve actuation options are available. The „standard“ actuation uses opposing 65psi control pressures to shift the valve into whichever state is desired. The new „normal Px“ option uses a spring to default the valve into measurement mode and 90psi to shift it into calibrate mode.

The electronics are designed around a high performance DSP processor to produce 64 channel data in excess of 850 Hz (readings per channel per second). “Fast mode” can achieve rates of 2500 Hz. The onboard flash holds the pressure-temperature matrix that converts raw A/D counts to precise engineering unit data over a wide range of temperatures. The power conditioning circuit allow a wide power supply range and minimize module self-heating.

The MPS makes communication simple by including an integrated web server and supporting a wide variety of protocols. The MPS also supports IEEE-1588v2 Precision Time Protocol. Leveraging this technology allows the user to synchronize multiple MPS units and any other devices supporting IEEE-1588 sub-microsecond resolve. While IEEE-1588 support essentially eliminates the need for an external trigger, the MPS still retains support for both a frame trigger and a scan trigger.

* When limiting the channel scan list to 16 channels using the “Fast Scan” feature



Removable input headers
(available with
0.031" and
0.042" tubes)

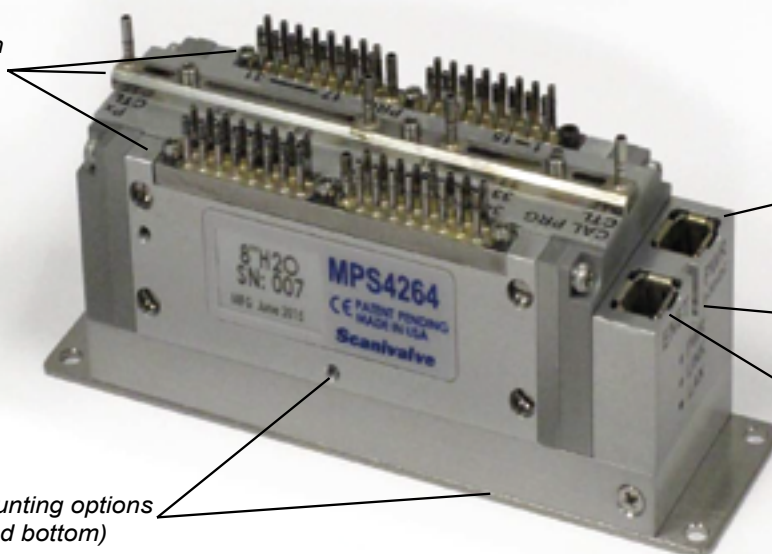

Power
Connection
(9-36 Vdc)

Power, Link &
LAN activity
lights

Ethernet
Connection

Multiple mounting options
(side and bottom)

■ APPLICATIONS

The MPS4264 electronic pressure scanning module is specifically designed for use in wind tunnel and flight tests where operational conditions are very space constrained and pressures do not exceed 50 psi. It is ideal for use inside small supersonic wind tunnel models.

The very low pressure ranges offered and small size also make it an ideal fit for wind engineering applications where the measurement pressures are very low.

It may be mounted in any position so the pressure sensors may be close coupled to the pressure sources to be measured. Removable headers allow for easy installation and removal without breaking the pneumatic lines.

When the MPS4264 is used for flight test, it must be installed in a Thermal Control Unit (TCU). This allows the unit to be operated in high vibration environments down to -50°C.

■ SUPPORTING ACCESSORIES

To make integration of the MPS4264 simple, Scanivalve has a full line of supporting accessories including:

- Desktop power supply, supporting 5 units
- Thermal Control Unit for extreme environments
- Miniature 4 and 8 port Ethernet Switch
- Custom Ethernet and power cables

■ COMMUNICATIONS

Communication to the MPS is through a miniature Ethernet connection with an impressive array of protocols. The user can connect to the MPS using a Web Browser. This graphical interface allows the operator to change settings, scan data to the screen or scan binary or ASCII data to a file on the host machine with a click of a mouse. The MPS can also stream data to an FTP server. ASCII commands may be issued via a Telnet client connected to the MPS Telnet server. A Multicast protocol is employed that allows multiple MPS devices to all start scanning in concert by sending a command to a single device. The MPS also supports a binary server that is optimized for a LabVIEW® interface. Example LabVIEW VIs are available.

The MPS uses the latest Precision Time Protocol (IEEE-1588v2) standard to time correlate data. This exciting protocol allows any 1588 slave device to synchronize its time to sub microsecond accuracy without the use of external trigger signals. PTP can synchronize any IEEE-1588 compliant physical measurement device or a computer to a common Grand Master time.



■ IMPROVED SENSORS, IMPROVED ACCURACY

The primary focus of the MPS4264 was to improve the unit's overall accuracy across the entire temperature range. Scanivalve worked directly with a leading sensor designer to create a custom sensor package specifically for the MPS scanner. This design uses two layers of RTV to isolate the pressure sensor from mechanical influences like those caused by thermal expansion or assembly. Piezoresistive sensors also change greatly in span and zero over temperature so we placed eight individual digital temperature chips in very close proximity to the sensors. Combined with the design placing the sensors in an aluminum housing in the center of the module to prevent rapid temperature changes, these chips allow us to accurately correct for any change in the sensor's behavior due to temperature.

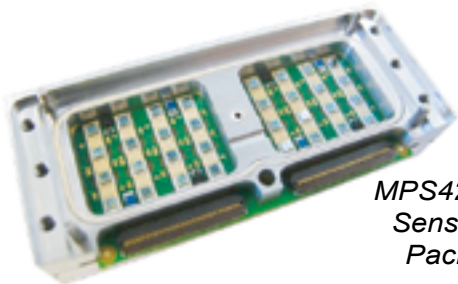

**MPS4264
Sensor
Pack**

Along with the pressure sensors, all components in the measurement circuit are effected by temperature and drift over time. Scanivalve designed a patent-pending architecture which continuously corrects for these changes over time, while the unit is scanning. This technique of "Dynamic Zero Correction" greatly improves the stability of the entire system over time and temperature. This is accomplished completely „behind the scenes,“ does not affect performance and requires nothing of the user. The advanced sensor technology, careful packaging and innovative „Dynamic Zero Correction“ function greatly improve the stability and repeatability of the system. With these improvements the need for zero offset calibrations (CALZ) and span calibrations is dramatically reduced. This results in fewer test interruptions, less down time and increased overall efficiency.

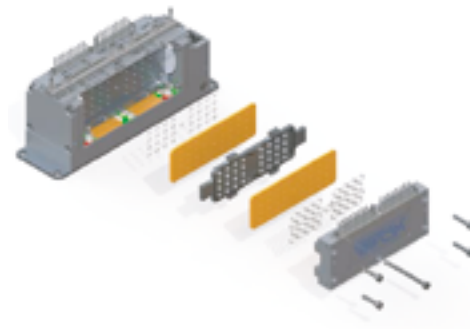

■ PNEUMATIC CALIBRATION VALVE

The valve design is a sliding-type valve. An aluminum shuttle, populated with self-lubricating O-rings cycles back and forth between two positions to achieve each of the pneumatic states. The „bearing plate“ between the sliding O-rings and the aluminum stationary portion of the valve is a proprietary compound that is extremely low friction. The O-rings are supported completely to prevent any deformation during a state change. The valve shuttle is supported on ball bearings to provide minimal friction and maximum support. This design allows for low actuation force and minimal "stiction" - meaning the actuation force does not noticeably increase after long periods of dormancy. Samples of the valve design were tested to over 1,000,000 cycles without maintenance.

Existing pressure scanners require outside pneumatic pressure as a force to switch the valve logic. In most applications, this „control pressure“ must be continuously supplied to the scanner to maintain the desired valve state. The MPS4264 offers a unique option with a valve that defaults to the „measurement“ mode, allowing sample pressures to be read without any outside pneumatic control pressure. This option, called „Normal Px,“ is another way the MPS4264 simplifies system architecture.

An optical valve position sensor has been integrated allowing the valve state to be queried with a simple software command.

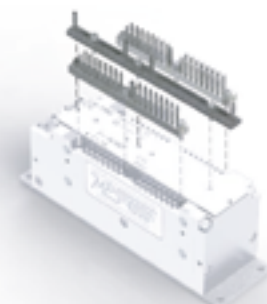

**Removable
pressure input
headers are
standard**



SPECIFICATIONS (for MPS4264 version)

Inputs (Px):	0.042" [1.067mm] OD (standard) 0.031" [.787mm] OD (optional)	Maximum Reference Pressure:	50 psig (345kPa)
Inputs (Cal, Ref, CTL, Prg):	0.063" [1.600mm] OD	Maximum Environment Pressure:	100 psia (690kPa absolute)
Full Scale Ranges:	4 inH ₂ O, 8 inH ₂ O, 1psid, 5psid, 15psid, 50psid [995.4Pa, 1990.7Pa, 6.89kPa, 34.5kPa, 103.4kPa, 344.7kPa]	Ethernet Connection:	100baseT, MDIX auto-crossing
Accuracy:	4 inH ₂ O: 0.20%FS 8 inH ₂ O: 0.15%FS 1psid: 0.06%FS 5psid: 0.06%FS 15psid: 0.06%FS 50psid: 0.06%FS	External Trigger:	5-15Vdc, 6.5mA
Overpressure Capability:	4 inH ₂ O: 25x 8 inH ₂ O: 15x 1psid: 15x 5psid: 10x 15psid: 5x 50psid: 2x	Data Output Rate: (samples/channel/second)	TCP/IP Binary: 850Hz "Fast Mode": 2500Hz
A/D Resolution:	24bit	Power Requirements:	9-36Vdc, 3.5W
Media Compatibility:	Gases compatible with silicon, silicone, aluminum, and Buna-N	Control Pressure Requirements:	65psi min. (CPx - standard) 90psi min. (NPx)
		Mating Connectors:	Ethernet: TE Connectivity PLG 8P8C Mini2 Power: TE Connectivity PLG 8P8C Mini1
		Weight:	6.59oz [186.9g]
		Operating Temperature:	0° to 70°C -50°C to 60°C with TCU
		Storage Temperature:	0° to 80°C

DIMENSIONS (for MPS4264 version) Inches [mm]

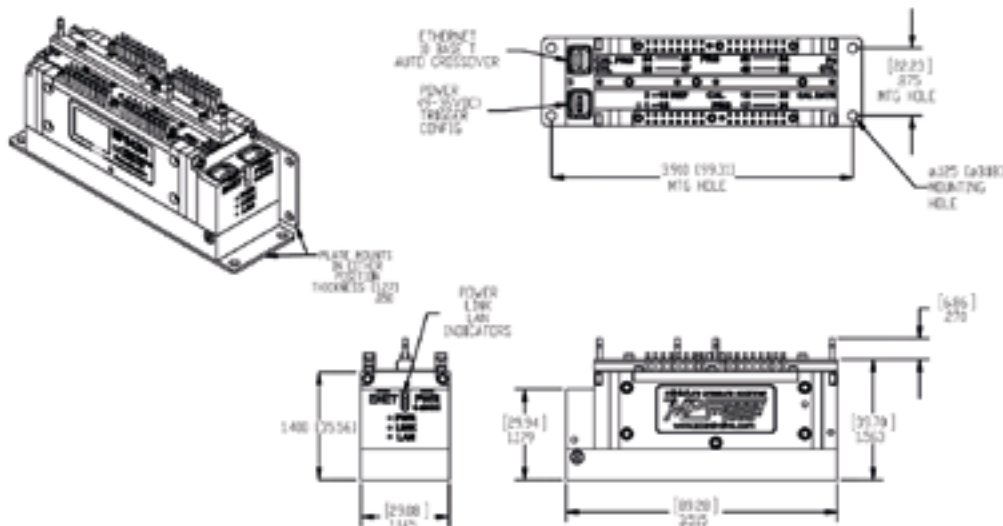

ORDERING INFORMATION

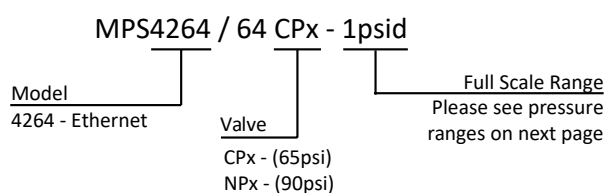

MPS4264's come standard with a 3ft MPS Power/Trigger flying leads cable and MPS Premium Ethernet cable.



MPS4264EPx

Miniature Pressure Scanner Electric Valve

FEATURES

- Integral processor for direct Ethernet connection
- New valve design provides „isolate-purge“
- Dynamic zero correction for unmatched sensor stability
- Electronic valve control eliminates the need for control pressures
- IEEE1588-2008v2 PTP compatible
- Up to 2,500 samples/channel/second*
- Simple LabVIEW® integration
- Removable input headers
- Integral web server

GENERAL DESCRIPTION

The MPS4264/EPx miniature pressure scanner represents the forefront of pressure measurement technology. It has been designed from the ground up with size, accuracy, and functionality in mind. It boasts 64 pressure channels, TCP/IP Ethernet connectivity, and a wealth of other features.

A new valve was designed that fully isolates the sensors from purge pressure and provides long term, maintenance free operation. Not only is the valve design an improvement over legacy products, but also introduces a new method of valve operation never before used in Scanivalve products.

The EPx was designed to be used in applications where a pneumatic supply for control pressure is inconvenient or unavailable. The NPx and CPx variants of the MPS4264 require pneumatic control pressure to change the valve state, where the EPx utilizes an internal motor to change the valve state. This electronic valve provides users with the ability to change the valve state from measurement mode to calibration/purge mode with a simple software command. An optical valve position sensor can also be queried with a software command to determine the valve position.

The power requirements and scanner footprint are the main differences when comparing the EPx to the typical



MPS4264/64EPx
Ethernet Pressure Scanner

CPx or NPx MPS4264 model. The internal motor that drives the valve requires a 18-36VDC to operate the electric valve.

The EPx version still maintains the same robust features that are found in the MPS4264 series scanners. Communication protocols remained unchanged. Precision Time Protocol is available for time correlated data, and scan data can be collected via TCP, FTP, or UDP at scan rates up to 2500Hz*. A TCU option is available for the MPS/EPx.

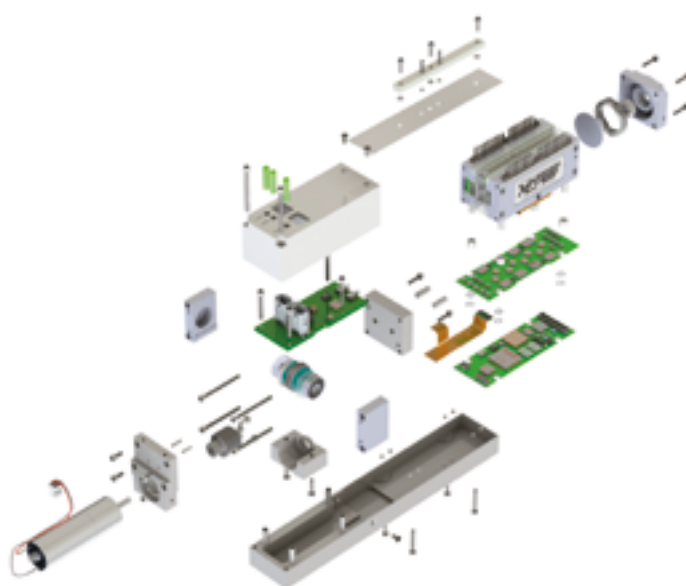

* When limiting the channel scan list to 16 channels using the „Fast Scan“ feature



SPECIFICATIONS (for MPS4264/EPx version)

Inputs (Px):	0.042" [1.067mm] OD (standard) 0.031" [.787mm] OD (optional)	Maximum Reference Pressure:	50 psig (345kPa)
Inputs (Cal, Ref, Prg):	0.063" [1.600mm] OD	Maximum Environment Pressure:	100 psia (690kPa absolute)
Full Scale Ranges:	4 inH ₂ O, 8 inH ₂ O, 1psid, 5psid, 15psid, 50psid [995.4Pa, 1990.7Pa, 6.89kPa, 34.5kPa, 103.4kPa, 344.7kPa]	Ethernet Connection:	100baseT, MDIX auto-crossing
Accuracy:	4 inH ₂ O: 0.20%FS 8 inH ₂ O: 0.15%FS 1psid: 0.06%FS 5psid: 0.06%FS 15psid: 0.06%FS 50psid: 0.06%FS	External Trigger:	5-15Vdc, 6.5mA
Overpressure Capability:	4 inH ₂ O: 25x 8 inH ₂ O: 15x 1psid: 15x 5psid: 10x 15psid: 5x 50psid: 2x	Data Output Rate: (samples/channel/second)	TCP/IP Binary: 850Hz "Fast Mode": 2500Hz
A/D Resolution:	24bit	Power Requirements:	18-36Vdc @ 5.5W (Required for valve transition)
Media Compatibility:	Gases compatible with silicon, silicone, aluminum, and Buna-N	Mating Connectors:	Ethernet: TE Connectivity PLG 8P8C Mini2 Power: TE Connectivity PLG 8P8C Mini1
		Weight:	0.804lbs [365g]
		Operating Temperature:	0° to 70°C
		Storage Temperature:	0° to 80°C
		Shock and Vibe:	MIL-STD 810G Curve H

DIMENSIONS (FOR MPS4264/EPx VERSION) INCHES [mm]

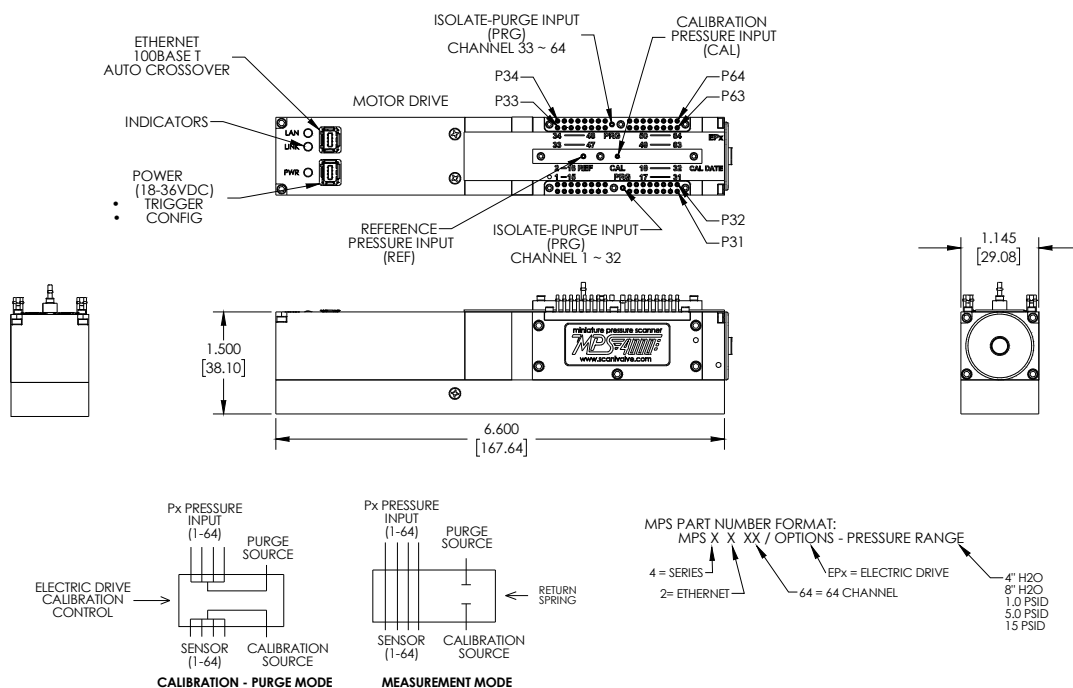



bar ES4000
Miniature Ethernet Switch



*ES4008 and ES4004
Miniature Ethernet switch*

FEATURES

- Supports up to four (4) or eight (8) MPS4264 miniature pressure scanners
- 9-36Vdc power
- Standard RJ45 uplink port
- 0°C to 70°C operating range

The ES4000 is an unmanaged Ethernet switch to support the Scanivalve MPS4264 series of Ethernet pressure scanners. It is designed specifically to be as small as possible to enable it to be installed in wind tunnel models along side MPS4264 scanners. This allows the user to simply bring a single Ethernet cable from the control network or host computer into the test article. This minimizes test setup time and the number of cables that must pass through the critical, high demand space in the sting. The ES4008 is a 9 port switch, providing support for 8 MPS4264 scanners and a single 'uplink' RJ45 connection back to the host computer or control network. The ES4004 is a 5 port version of similar design.

The aluminum case provides a rugged, reliable package. All connectors, both power and Ethernet are latching to provide reliable connections in high vibration environments. Multiple threaded mounting holes as well as the overall small size and light weight make installation flexible and easy.

SPECIFICATIONS

Dimensions:

ES4004:	2.415 x 1.450 x 1.079
ES4008:	3.3125 x 1.450 x 1.078
	(inches, L x W x H)

Weight: 0.24lbs (110g)

Input Voltage: 9-36Vdc

Power Consumption: 2W, maximum

Ethernet Uplink: RJ45, 100BaseT

Mating Connectors

Ethernet Uplink: RJ45

Ethernet: TE Connectivity PLG 8P8C Mini2

Power: TE Connectivity PLG 8P8C Mini1

Maximum Ambient Pressure: 100psia

Operating Temperature: 0°C to 70°C

Humidity: 5 to 95% RH, non-condensing

Shock & Vibration: MIL-STD-810G
Category 24

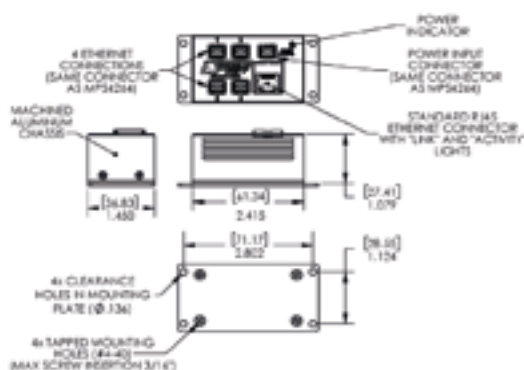

ES4004

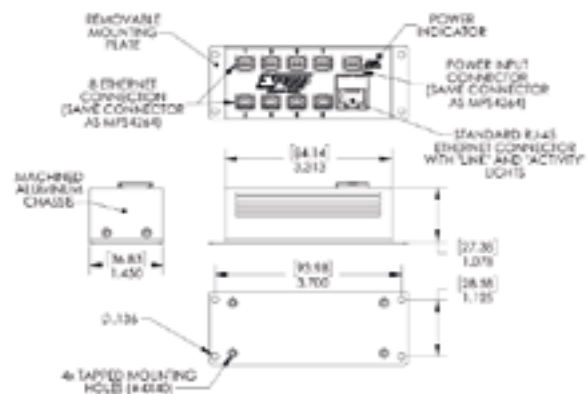

ES4008



bar MPS4264TCU
Thermal Control Unit

FEATURES

- Maintains a stable temperature environment for MPS4000 series pressure scanners
- Quick disconnects for electrical and pneumatic I/O
- Rugged IP-54 rated aluminum case
- Available for:
MPS4264 Ethernet Scanner - NPx, CPx, or EPx

GENERAL DESCRIPTION

The MPS (Miniature Pressure Scanner) line of Thermal Control Units is designed to provide a controlled temperature environment for MPS4264 series electronic pressure scanners. The MPS4000 series pressure scanners incorporate temperature compensated piezoresistive pressure sensors which must remain in a controlled temperature environment to provide the most accurate pressure measurement. All MPSTCU's include a rugged anodized aluminum enclosure, single pneumatic connector, mating pneumatic connector, a single electrical/data connector, and breakout cable with flying leads.

The MPSTCU offers an optional heater circuit for use in environments as cold as -60°C. This heater circuit utilizes two 20 watt heaters to keep the MPS4264 scanner within its temperature compensated range (0-70°C). Exceeding the compensated temperature range can induce errors in the pressure measurements.

For higher temperature applications (60-125°C) the Cooling Kit variant of the MPSTCU is required. The cooling kit variant contains the same heater circuit as the heater only MPSTCU variant. With the addition of the cooling kit, the MPSTCU can keep the MPS in the compensated range while the environmental temperatures range from -60°C to 125°C. Approximately 3.0 CFM of 23°C cooling air is required to properly cool the MPS while subject to the 125°C environment.



The electrical connector on the for the MPS4264TCU (Ethernet) is a 17 contact M12 series connector which provides module power, heater power, scan triggering, and Ethernet data.

The pneumatic connector on all MPSTCU's is a Scanivalve 70MPS series connector. These features make for easy use and adaptability when implementing the MPSTCU into a complex system.

APPLICATION

Thermal Control Units are most commonly utilized in flight test, automotive, wind turbine, wind tunnel, and engine test applications where temperatures tend to vary and are often extreme.

Thermal Control Units may also be used anywhere a stable temperature environment is not available for MPS pressure scanners. Although the environmental temperatures are within the compensated range of the scanner, a Thermal Control Unit can be used to improve measurement accuracy and limit any effects from temperature.

Thermal Control Units also provide a ruggedized enclosure to protect the scanner's components from moisture, dust, debris, and other contaminants that could harm the scanner.



SPECIFICATIONS (MPS4264TCU FOR NPX OR CPX)

Mechanical Capacity: MPS4264/64CPx
MPS4264/64NPx

Case Material: 6063 Anodized Aluminum

Operating Temperature Range: -60°C to +125°C*

Pneumatic I/O: 70 Port connector with 0.063" tubulations (standard) or 70 Port connector with 0.040" tubulations** (optional)

Electrical I/O: 17 contact M12 Series

Heater Rating: Two 20 watt heaters

Power Required:
Without heater: 9-36Vdc, 3.5W
With heater option: 20-30Vdc, 45W

Cooling Air Required (125°C Environment): 3.0 CFM

Temperature Sense: 4 wire RTD

Mounting Position: Any

Ingress Protection: IP-54 rating

Shock and Vibration: MIL-STD-810G Category 24

Weight:
(Including MPS Scanner and connector)
MPS4264TCU 1.97 lbs. (.89 kgm)

Minimum Environmental Pressure:
MPS4264TCU 0.5psia

ORDERING INFORMATION

MPS4264TCU-X

Where **X** is:
-1 MPS4264TCU with Cooling Kit and Heater
-2 MPS4264TCU with Heater Only
-3 MPS4264TCU no Heater or Cooling Kit

*Scanivalve recommends use of the MPS4264TCU with Cooling Kit in environments above 60°C. 3.0 CFM of 23°C cooling air is required at 125°C.
 **Px inputs are 0.040" tubulations. CAL, REF, CALCTL, PXCTL and PURGE are 0.063" tubulations

DIMENSIONS INCHES [mm]

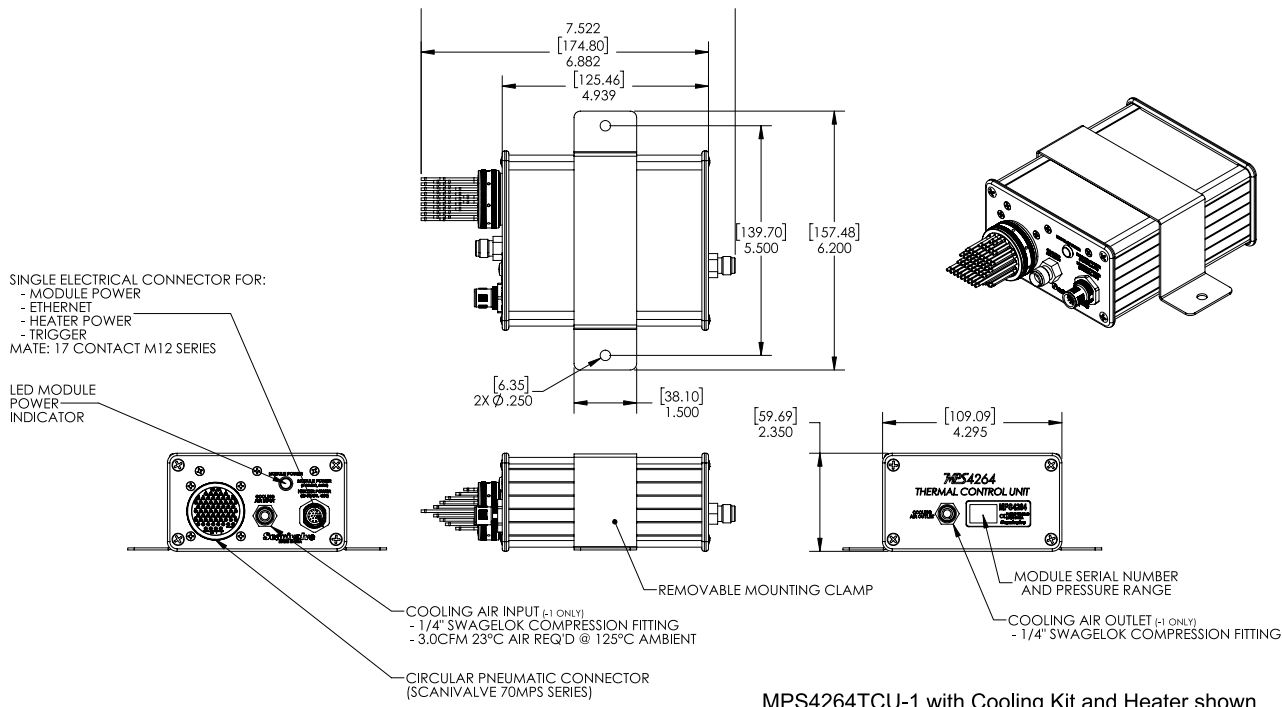

MPS4264TCU-2
Thermal Control Unit





SPECIFICATIONS (MPS4264TCU FOR EPX)

Mechanical Capacity: MPS4264/64EPx
Case Material: 6063 Anodized Aluminum
Operating Temperature Range: -60°C to +125°C*
Pneumatic I/O: 70 Port connector with 0.063" tubulations (standard) or 70 Port connector with 0.040" tubulations** (optional)
Electrical I/O: 17 contact M12 Series
Heater Rating: Two 20 watt heaters
Power Required:
 Without heater: 18-36Vdc, 5.5W
 (Required to operate electric valve)
 With heater option: 20-30Vdc, 45W
Cooling Air Required (125°C Environment): 3.0 CFM
Temperature Sense: 4 wire RTD
Mounting Position: Any

Ingress Protection: IP-54 rating
Shock and Vibration: MIL-STD-810G Category 24
Weight:
 (Including MPS Scanner and connector)
 MPS4264TCU/EPx 2.93 lbs. (1.33 kgm)
Minimum Environmental Pressure:
 MPS4264TCU/EPx 0.5psia

ORDERING INFORMATION

MPSTCU Electric Valve - X

Where **X** is:

- 1 MPS4264TCU with Cooling Kit and Heater
- 2 MPS4264TCU with Heater Only
- 3 MPS4264TCU no Heater or Cooling Kit

*Scanivalve recommends use of the MPS4264TCU with Cooling Kit in environments above 60°C. 3.0 CFM of 23°C cooling air is required at 125°C.

**Px inputs are 0.040" tubulations. CAL, REF, CALCTL, PXCTL and PURGE are 0.063" tubulations

DIMENSIONS INCHES [mm]

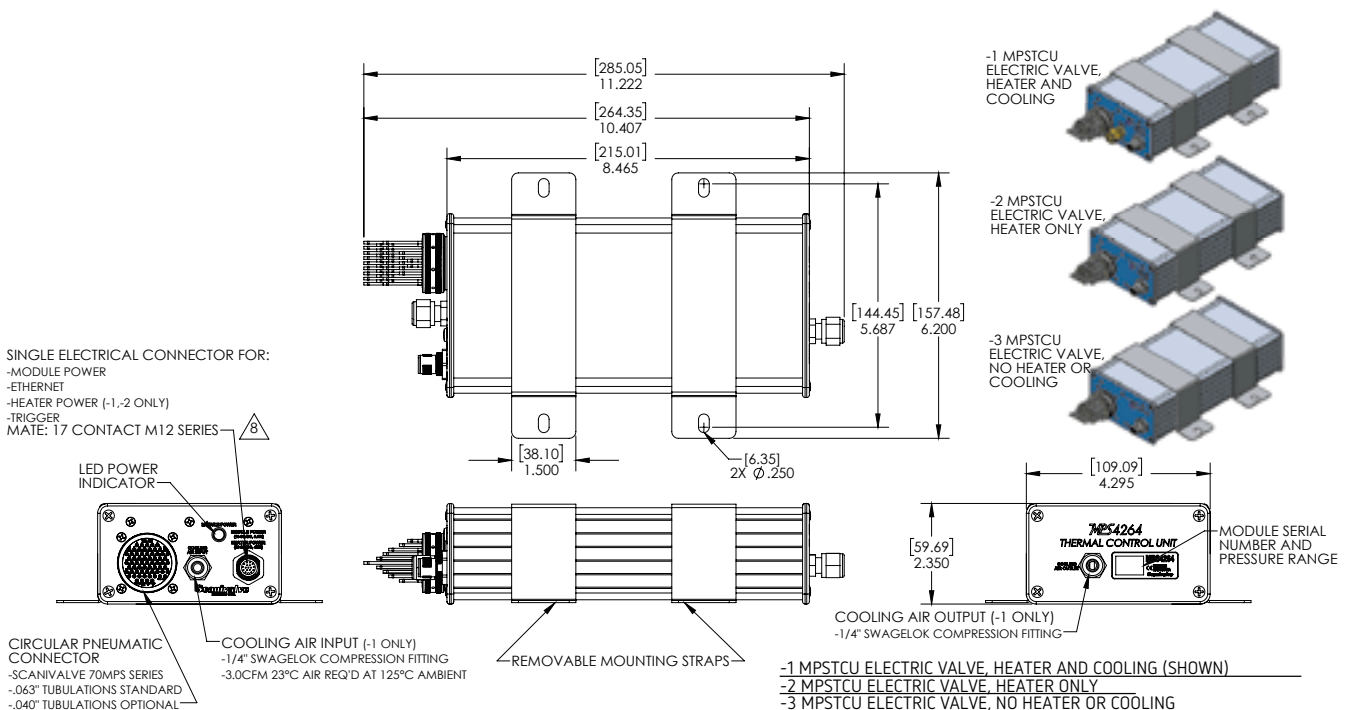



bar MPS4232
Miniature Pressure Scanner

FEATURES

- Integral processor for direct Ethernet connection
- Dual-core processor
- IEEE1588-2008 PTPv2 compatible
- Data rates up to 2500Hz (samples/channel/second)
- Removable input header
- Wide operating voltage (5-36Vdc)
- Integral web server
- Dynamic zero correction for unmatched sensor stability
- One 24 bit A/D per channel for synchronous scanning
- Simple LabVIEW® integration

GENERAL DESCRIPTION

The MPS4232 miniature pressure scanner represents the forefront of pressure measurement technology. It has been designed from the ground up with size, accuracy, and functionality in mind. It boasts 32 discrete pressure channels, small footprint, TCP/IP Ethernet connectivity, and a wealth of other innovative features.

The MPS4232 is designed around a core sensor layout that uses a custom packaged, ultra-stable sensor. Scanivalve engineers evaluated known causes of non-repeatability in piezoresistive pressure transducers and designed a double isolation method of bonding the sensors to the base substrates (patented) that minimizes the mechanical influences of assembly and thermal expansion. This process dramatically improves the stability and the resulting accuracy of the sensors.

Scanivalve engineers also developed a proprietary means of maximizing sensor stability for span and offset. This technique of “Dynamic Zero Correction” greatly improved the sensor’s stability over time and temperature (patented). The increase in overall sensor stability reduces the need for zero offset and span calibrations, resulting in significantly reduced test interruptions and down time.

The electronics are designed around a high performance dual-core processor which can produce engineering unit



MPS4232 Ethernet Pressure Scanner

data for 32 channels in excess of 850 Hz (samples per channel per second). The onboard flash memory holds the pressure-temperature matrix that converts raw A/D counts to precise engineering unit data over a wide range of temperatures. The power conditioning circuit allows for a wide power supply range and minimizes module self-heating.

The MPS makes communications simple by including an integral web server and supporting a wide variety of standard protocols. The MPS also supports IEEE1588v2 Precision Time Protocol: an Ethernet based, time synchronization method. Leveraging this technology allows the user to synchronize multiple MPS units, or other devices that support IEEE1588v2, to sub-microsecond resolve. While IEEE1588v2 support essentially eliminates the need for external triggering, the MPS still retains the support for an external frame or scan trigger.

APPLICATIONS

The MPS4232 electronic pressure scanning module is specifically designed for use in wind tunnel and flight test applications where operational conditions are very space constrained and pressures do not exceed 50 psi. It is ideal for use inside small supersonic wind tunnel models. The available low pressure ranges and small size also make it an ideal fit for wind engineering applications where the measurement pressures are very low.



SMALL PACKAGE, BIG FEATURES

The goal of the MPS4232 was to provide a high-channel, Ethernet intelligent pressure scanner in a small package that could be used in applications where the scanner may be mounted inside of test articles, wind tunnel models, or as close to the measurement ports as possible. In dynamic pressure measurement applications, the ability to mount the MPS4232 near the measurement ports helps alleviate the concerns regarding pneumatic frequency response. While the package may be small, the MPS4232 boasts many instrumental and favorable features:

- All electronics in the MPS4232 are contained to a single board.
- Dual-core processor, which yields faster EU conversions and scanner operations with low overhead.
- Each channel has a discrete sensor and each sensor has a dedicated 24 bit Analog-to-Digital converter, providing synchronous data collection across all 32 channels with high resolution.
- A wide operating voltage. As little as +5Vdc from a USB port needed to power the MPS.
- No moving parts which nearly eliminates any maintenance.
- Removable input header (PX and REF) which can be used as a quick-connect point for different test areas, module change-out, or plumbing harnesses.
- Optional 90° removable input headernetwork, these trigger outputs can be synchronized to the IEEE1588 "Grandmaster."

Like the digital inputs, both +5Vdc as well as the input power (9-36Vdc) is provided at the digital output connector. This provides the user with a wide range of voltage options for the digital outputs as well as simple wiring and connection options. The status of each digital output can be displayed on the front of the ECM4000 with an indicator LED. Both digital input and digital outputs are designed to operate as

part of 'scripts' that are created by the user. Digital inputs can be used as triggers to initiate or stop various scripts, and digital outputs can be use as parts of the scripts to operate various aspects of the system such as cycle valves or manage indicators. In addition to the external digital inputs and outputs, the ECM4000 also includes 3 internal solenoids. These are operated through separate, dedicated digital outputs. These can be controlled manually/ directly or configured to operate as part of a user-created script.

IMPROVED SENSORS, IMPROVED ACCURACY

The primary focus of the MPS4232 was to improve the unit's overall accuracy across the entire temperature range. Scanivalve worked directly with a leading sensor designer to create a custom sensor package specifically for the MPS scanner. This design uses two layers of RTV to isolate the pressure sensor from mechanical influences like those caused by thermal expansion or assembly. Piezoresistive sensors also change greatly in span and zero over temperature, so we placed eight individual RTDs in very close proximity to the sensors. These RTDs allow the MPS to accurately correct for any change in the sensor's behavior due to temperature. Along with the pressure sensors, all components in the measurement circuit are effected by temperature and drift over time. Scanivalve designed a patented architecture which continuously corrects for these changes over time, while the unit is scanning. This technique of "Dynamic Zero Correction" greatly improves the stability of the entire system over time and temperature. This is accomplished completely „behind the scenes,“ does not affect performance and requires nothing of the user.

The advanced sensor technology, careful packaging and innovative „Dynamic Zero Correction“ function greatly improve the stability and repeatability of the system. With these improvements the need for zero offset calibrations (CALZ) and span calibrations is dramatically reduced. This results in fewer test interruptions, less down time and increased overall efficiency.

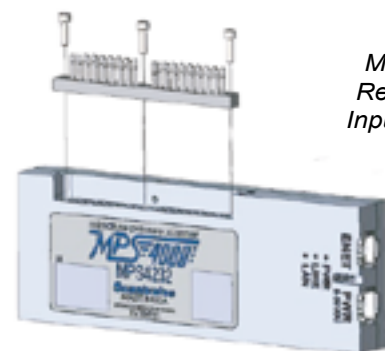

**MPS4232
Removable
Input Header**



COMMUNICATIONS

Communication to the MPS is established through a latching miniature Ethernet connection, and offers an impressive array of available protocols.

The MPS is built with a integral web server that can be accessed using a web browser. This provides an easy-to-use graphical interface that allows the operator to change settings, scan data to the screen, or scan and collect binary or ASCII data to a file that can be saved to the host machine - all with the click of a mouse.

The MPS can stream data to an FTP server or Network Attached Storage device (NAS), a TCP/IP client, or a UDP client. ASCII commands may be issued via a TCP/IP Telnet client connected to the MPS Telnet server. A Multicast protocol is employed that allows multiple MPS devices to all start scanning in concert by sending a command to a single device. The MPS also supports a binary server that is optimized for a LabVIEW® interface. Example LabVIEW® VIs are available.

The MPS uses the latest Precision Time Protocol (IEEE1588 PTPv2) standard to time correlate data. This protocol allows any 1588 slave device to synchronize its time to sub-microsecond accuracy without the use of external trigger signals. Precision Time Protocol can synchronize any IEEE1588v2 compliant physical measurement device or a computer to a common Grand Master time.

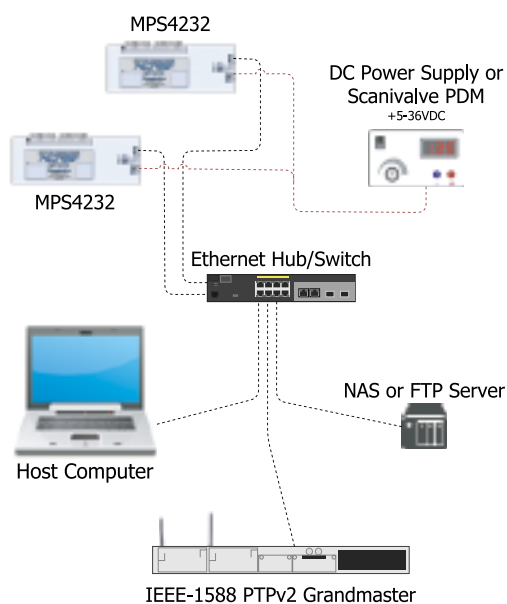

SUPPORTING ACCESSORIES

The MPS4232 is shipped with most accessories required for operation: a 3ft long cable with flying leads (1) is provided for the power and external trigger connections, a 3ft long Ethernet extender cable (2) is provided for Ethernet communications. Power requirements are wide (5-36Vdc) so many DC power sources are suitable to power the MPS4232.



MPS4232 & SUPPLIED ACCESSORIES*

In addition to the standard accessories provided, Scanivalve offers several other supporting accessories including:

- PDM1500 - Single power supply
- MPSPDM4500 - 5 port power supply
- Power cables in lengths up to 150 ft (46m)
- Power cables with trigger and serial connections in lengths up to 150ft (46m)
- Ethernet cables in lengths up to 100 ft (30m)
- ES4000 series miniature Ethernet switches (4 or 8 port)
- Spare standard Px Input or 90° MPS Input Header
- Calibration Header

These accessories can be purchased from Scanivalve to enable quick and easy setup of the system. Please see the Module Accessory Catalog for a complete selection of all available MPS accessories and part numbers.

* Supplied accessories may differ in color or appearance. LabVIEW® is a registered trademark of National Instruments.



SPECIFICATIONS

Inputs (Px): 0.042" [1.067mm] OD (standard)
0.031" [.787mm] OD (optional)

Reference Input (REF): 0.063" [1.600mm] OD

Full Scale Ranges: 4 inH₂O, 8 inH₂O, 1psid, 5psid, 15psid, 50psid
[995.4kPa, 1990.7kPa, 6.89kPa, 34.5kPa, 103.4kPa, 344.7kPa]

Accuracy*: 4 inH₂O: 0.20%FS
8 inH₂O: 0.15%FS
1psid: 0.06%FS
5psid: 0.06%FS
15psid: 0.06%FS
50psid: 0.06%FS

Overpressure Capability: 4 inH₂O: 25x
8 inH₂O: 15x
1psid: 15x
5psid: 10x
15psid: 5x
50psid: 2x

A/D Resolution: 24-bit

Maximum Reference Pressure: 100 psig (345kPa)

Maximum Environment Pressure: 100 psia (690kPa absolute)

Ethernet Connection: 100baseT, MDIX auto-crossing

External Trigger: 5-15Vdc±.5mA

Data Output Rate: Binary: 2500Hz
(samples/channel/second) ASCII: 100Hz

Power Requirements: 5-36Vdc, 3.5W

Mating Connectors: Ethernet: TE Connectivity PLG 8P8C Mini2
Power: TE Connectivity PLG 8P8C Mini1

Weight: 0.19lbs [86.2g]

Operating Temperature: 0° to 70°C

Storage Temperature: 0° to 80°C

Media Compatibility: Gases compatible with silicon, silicone, aluminum, and Buna-N

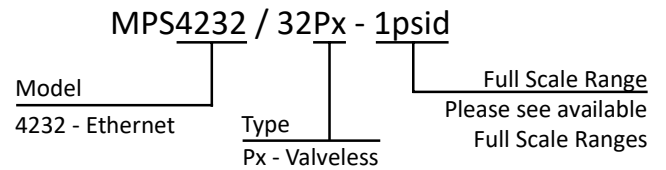

* Non-standard pressure ranges may result in a reduction of accuracy. Please contact Scanivalve for more information.

DIMENSIONS INCHES [MM]

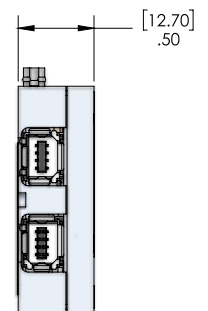
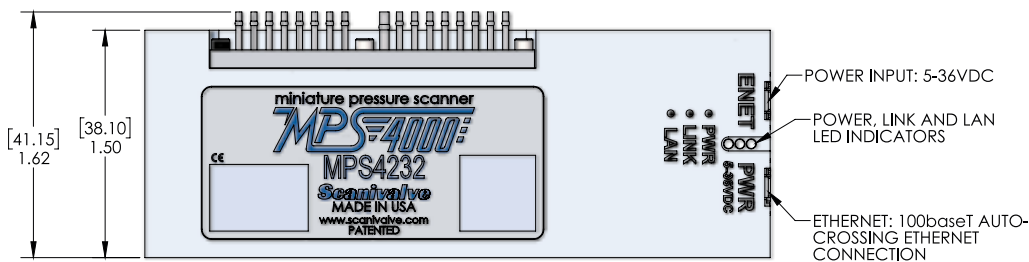
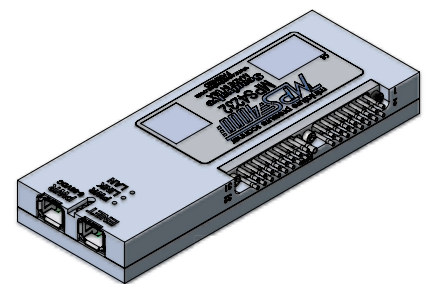
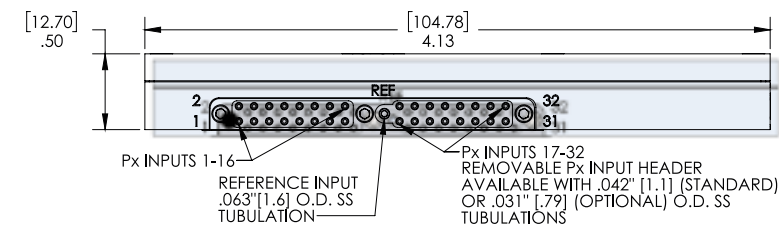

■ ACCESSORIES



■ MPS4264- ETHERNET MINIATURE PRESSURE SCANNER

The MPS4264 is a unique 64 channel pressure scanner versatile enough to be used for many applications. It is the perfect choice where space is limited such as wind tunnel models where it is also important to keep tubing length as short as possible. Significant improvements have been made in this next generation product with regard to accuracy when used in dynamic temperature environments. This also makes the MPS an excellent choice for flight test or other demanding applications.

- 64 channels
- Integral processor for direct Ethernet connection
- Scan rates up to 2500Hz
- IEEE1588-2008v2 PTP Compatible
- Integral web server
- Dynamic zero correction for unmatched sensor stability
- New valve design provides "isolate-purge"
- Wide operating voltage (9-36Vdc)





MPS CAL/REF HEADER KIT

The MPS CAL/REF Header Kit allows users to quickly change tubing between model measurements. By simply replacing the CAL/REF header, the user can quickly attach control, CAL, and REF pressure tubes to the module without the need to physically plumb each tube to the module. The MPS CAL/REF Header kit consists of one Header, and three cap screws.

- PN: 20463-01(NPx) or 20463-02 (CPx)
- Available in 0.063"
- Allows for quick tubing change
- Available for CPx and NPx modules



MPS PX INPUT HEADER KIT

The MPS Px Input Header Kit allows users to quickly change tubing between model measurement. By simply replacing the input headers, the user can quickly attach 64 different pressure tubes to the module without the need to physically plumb each tube to the module. The MPS Px Input Header kit consists of two Input Headers, and six cap screws. PN: 20462-01

- Available in 0.040" and 0.031"
- Allows for quick tubing change



MPS PLUMBING DUMMY

The MPS Plumbing Dummy eliminates downtime of an MPS4264 when a model shop would typically need to plumb a MPS into a model. PN: 20435-01

- Exact size dimensionally as an MPS4264 Scanner
- All mounting holes the same as an actual MPS4264 allowing
- for use of the mounting plate on the side or bottom
- Allows standard Px and Control headers to be installed
- O-ring seal of the Px headers allows leak tests to be performed
- Cutouts for electrical connectors
- Headers not included



POWER CABLE OPTIONS

The MPS offers multiple power cable options made from extremely flexible wire. These small diameter cables (.160 inch/4.1mm O.D) are protected by a PVC jacket and have a maximum operating temperature of 105°C.

- PN: 156085-01 Premium MPS Power, Serial, and Trigger cable utilizes connectors at both ends and is intended for use between an MPS or ES4000 and the MPSPDM4500. Cable length must be specified at time of order (150 ft maximum length).
- PN: 155625-01 MPS Power/Trigger Cable is a small diameter cable with flying leads and comes as a standard accessory with each MPS. The standard length of this cable is 3ft. This cable can be purchased separately and is intended for users who choose to supply their own power to the MPS or ES4000. (150 ft maximum length)



PN: 156085-01



PN: 155625-01

ETHERNET CABLE OPTIONS

Multiple Ethernet cable options are available for the MPS. The cables labeled as "Premium" utilize the highly flexible wire. The "Premium" cables are small diameter (.160 inch/4.1mm O.D.) cables protected by a PVC jacket and have a maximum operating temperature of 105°C.

- PN:156091-01 Premium MPS Ethernet Patch Cable (MPS-ES4000) is intended for use between an MPS and an ES4000 switch. This small diameter cable complements the compact size of the MPS and ES4000 (150 ft maximum length).
- PN:156062-01 Premium MPS Ethernet Patch Cable (MPS-RJ45) is intended for use between an MPS and any standard network hub, switch, or host computer (150 ft maximum length).
- PN: 155635-xx MPS Ethernet Patch Cable (MPS-RJ45) is a standard quality patch cable intended for use between an MPS and any standard network hub, switch or host computer. Standard lengths are 10, 25 and 100 ft. (Not Pictured)
- PN: 156110-01 MPS Ethernet Extender Cable (MPS to RJ45 Female) is a standard quality cable intended to be used with an MPS and an existing patch cable. This cable comes as a standard accessory with each MPS. The standard length of this cable is 3ft.



PN: 156091-01



PN: 156062-01



PN: 156110-01



POWER SUPPLY - 5 PORT

The five port MPS power supply allows for multiple MPS modules or the ES4000 to be powered by a single supply. This makes powering the modules convenient whether on the workbench, in the wind tunnel, or during flight test. This 5 port supply offers a single serial connection for the module plugged into the first position for advanced module configuration. PN:20030-01

- Provides power for up to 5 MPS or ES4000 modules
- 90-240 VAC/ 50-60 Hz input
- 24 Vdc output
- Serial and trigger connections on rear panel
- Rugged aluminum case
- Individual power switch for each port



POWER SUPPLY

The MPSPDM4000 and MPSPDM4100 power supplies allow for a single MPS module or ES4000 to be powered. These individual power supplies are an excellent choice for users that utilize a single MPS. The MPSPDM4100 allows for a serial connection as well as external scan triggering capabilities, while the MPSPDM4000 provides power only. MPSPDM4000 PN:20046-01, MPSPDM4100 PN:20045-01

- Provides power for a single MPS or ES4000 module
- 90-240 VAC/ 50-60 Hz input
- 24 Vdc output
- Serial and trigger connections available on MPSPDM4100



MPS BLANKING COVER

The MPS Blanking Cover allows for the MPS to be removed from a test section and stored in a safe location, without having to unplumb the module. Simply remove the headers and install the blanking cover over the pneumatic inputs. MPS Blanking Cover PN:20437

- Covers all pneumatic and electrical connectors when not in use
- Leaves CAL and REF input ports open to atmosphere to prevent unexpected pressurization of the sensors
- Compatible with CPx and NPx variants
- Works with the mounting plate mounted on the bottom or side



MPSTCU BREAKOUT BOX

The MPSTCU Breakout Box allows users of the MPSTCU a simple means to connect Ethernet, trigger, and module/heater power to the MPSTCU. The MPSTCU Breakout Box power connector is compatible with Scanivalve PDM1500 and PDM3200 power supplies while the Ethernet connector accepts a standard RJ-45 patch cable.

- Rugged aluminum case
- Mounting strap included as a standard accessory





















THE RIGHT SOLUTION FOR YOUR REQUIREMENTS

Due to our decades of experience, we at Althen can supply our customers with developments ranging from standard and customer-specific sensors to complete measuring systems.

All physical parameters are represented in our product range, using different technologies so that you always get the best solution for your measurement requirements. Thanks to our many years of experience, our technical know-how, our strong team of engineers with different professional backgrounds and our broad product range, we can offer the most efficient solutions for almost all applications in all branches of industry.

Our team will be happy to advise you. You can reach us by phone at **+49 6195 70060** or by e-mail to **sales@althen**.

OUR PRODUCT SCOPE

 bar	Pressure	 mm	Displacement	 g	Acceleration		Amplifier
 N	Force	 α	Rotation	 m/s^2	Vibration		Data Logger
 Nm	Torque		Joystick	 %/s	Angular Rate		Automation
 ϵ	Strain		Inclination	 °C	Temperature		Measurement Solutions



ALTHEN SENSORS & CONTROLS

■ Germany | Switzerland | Austria

ALTHEN GmbH Mess- und Sensortechnik
Dieselstraße 2
65779 Kelkheim
Germany
Phone: +49 6195 7 00 60
Email: info@althen.de

■ Netherlands | Belgium | Luxembourg

ALTHEN Sensors & Controls B.V.
Verrijn Stuartlaan 40
2288 EL Rijswijk
Netherlands
Phone: +31 70 3 92 44 21
Email: sales@althen.nl

■ France

ALTHEN / DB Innovation
26, avenue de la Méditerranée
34110 Frontignan
France
Phone: +33 4 67 78 61 66
Email: info@althensensors.fr

■ USA | Canada

ALTHEN Sensors & Controls Inc
2340 Littler Lane
Oceanside CA 92056
USA
Phone: +1 858 6 33 35 72
Email: info@althensensors.com

■ Sweden

ALTHEN Sensors & Controls AB
Gjuterivägen 10
76140 Norrtälje
Sweden
Phone: +46 8 7 95 24 90
Email: info@althensensors.se

Version | 03.2022



Further information can be found at althen.de