



bar

APR3915 PROTRAN® Dual Redundant Subsea Pressure Transmitter

SPECIFICATIONS

- Two pressure sensors and electronics for reliable dual redundancy
- Silicon-on-Sapphire sensor technology for outstanding performance
- Submersion to 3,000 metres sea level
- Pressure ranges available to 1,000 bar
- High accuracy option
- Hyperbaric testing to 3,300 metres depth
- Environmental Stress Screening (ESS Testing)



The APR3915 Dual Redundant Subsea pressure transmitter has been designed to meet the requirements of the sub-sea oil industry Valve- Mountable and is configured to mount directly to the industry standard control valve flange arrangement.

The unique Silicon-on-Sapphire sensor technology provides outstanding performance and gives excellent stability over a wide temperature range. The advanced sensor design consists of a piezoresistive silicon strain gauge circuit, which is epitaxially grown onto the surface of a sapphire diaphragm to form a single crystalline structure. The sapphire sensor element is then molecularly bonded to a titanium alloy sub-diaphragm. This enables the sensor to endure higher over-pressures and provides superb corrosion resistance. The sensor exhibits virtually no hysteresis and excellent long-term stability. With outstanding insulation properties, the sapphire substrate allows the sensor to operate over a very wide temperature range without loss of performance.

Housed in fully welded body with wetted parts conforming to the NACE recommendation for material corrosion resistance, this product will provide a durable solution for long term accurate pressure measurement even when permanently situated in extreme depth sub-sea environments. The pressure connection is achieved with an 8mm diameter stem with integral dual redundant o-ring seal grooves. Optional

connections are available. Alternative connections are available. The fitting is constructed from Inconel 625 for high chemical resistance. Providing a two wire output signal of 4-20 mA with high stability and repeatability for pressure ranges up to 1,000 bar. Intended for permanent immersion in pressurised dielectric oil and protected from ingress with a high pressure glass-to-metal lead through the product can withstand external pressure up to 3,000 metres depth water and provides secondary pressure containment up to 1,650 bar. Units can be supplied with hyperbaric test certificates to 3,000metres water submersion. Electrical connection is via strong PTFE Raychem Flexlite leads. Pressure ranges available from 0-200 bar to 0-1,000 bar.

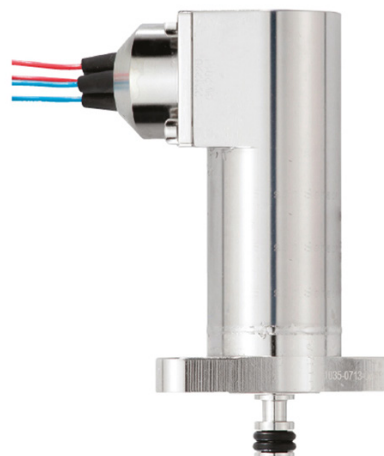



■ DIMENSIONS (in mm)

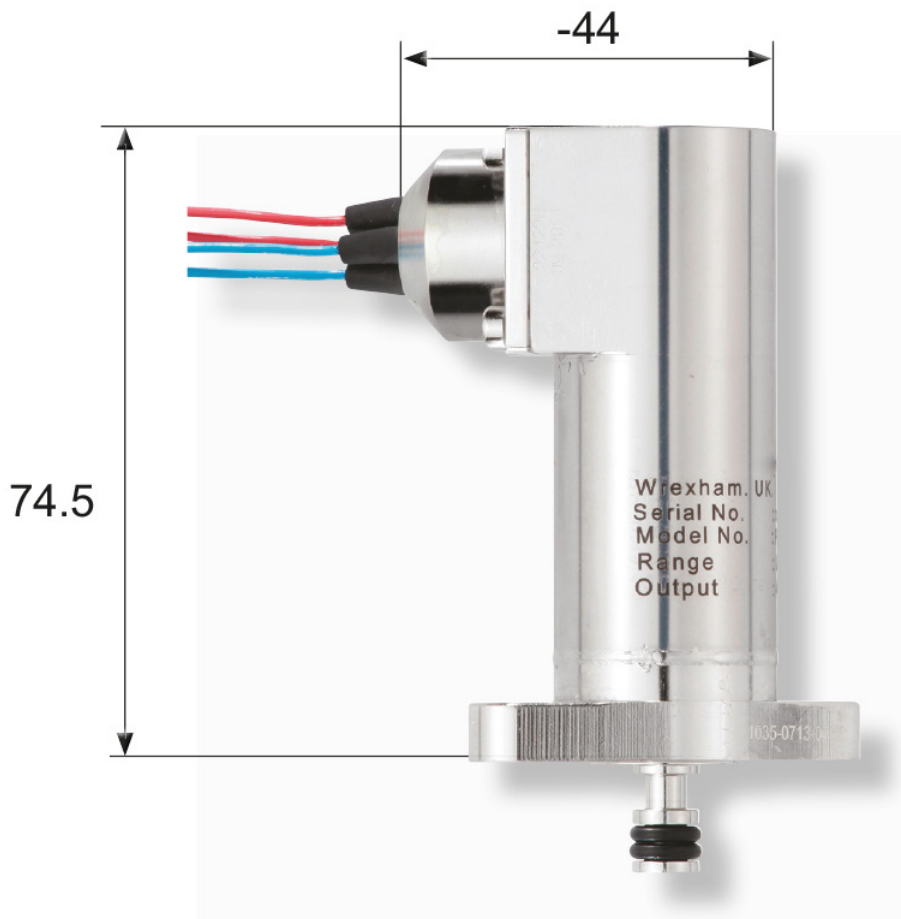



TECHNICAL DATA

Type	APR3915
Sensor Technology:	Silicon-on-Sapphire (SoS)
Output Signal:	4 – 20 mA (2 wire)
Supply Voltage:	10 – 36 VDC
Pressure Reference:	Sealed gauge
Protection of Supply Voltage:	Protected against supply voltage reversal up to 50 V
Standard Pressure Ranges:	0 – 569 bar; 0 – 759 bar; 0 – 1,035 bar; 0-1,380 bar (other options available)
Overpressure Safety:	2x for ranges up to 759 bar; 1.5x for 1,035 bar
Load Driving Capability:	4 – 20 mA: $RL < [UB - 10 V] / 20 \text{ mA}$ (e.g. with supply voltage (UB) of 36V, max. load (RL) is 1300 Ω)
Accuracy NLHR:	$\leq \pm 0.25 \%$ of span BFSL
Zero Offset and Span Tolerance:	$\pm 0.10 \text{ mA}$
Operating Ambient Temperature:	-20°C to +40°C (-4 °F to +104 °F)
Operating Media Temperature:	-20°C to +40°C (-4 °F to +104 °F)
Storage Temperature:	+5 °C to +40 °C (+41 °F to +104°F) Recommended Best Practice
Temperature Effects:	$\pm 0.015\%$ fs total error band for -20° to +40°C; Typical thermal zero and span coefficients $\pm 0.005\%$ FS/°C.
ATEX/IECEX Approval Option:	Ex II 1 G Ex ia IIC T4 Ga (zone 0) Ex II 1 D Ex ia IIIC T135 °C Da (zone 20) Ex I M 1 Ex ia I Ma (group 1 M1)
ATEX/IECEX Safety Values:	$U_i = 28 \text{ V}$ $I_i = 119 \text{ mA}$ $P_i = 0.65 \text{ W}$ $L_i = 0.1 \mu\text{H}$ $C_i = 74 \text{ nF}$ Temperature Range = -20 °C to +70 °C Max. cable length = 45 m
Ingress Protection:	Fully welded housing. Rated IP67 when correctly installed to conduit connection.
Electromagnetic Compatibility:	Emissions: EN61000-6-4; Immunity: EN61000-6-2; Certification: CE Marked
Insulation Resistance:	> 500 M Ω @ 50 VDC
Response time 10-90 %:	1 mS
Wetted Parts:	SAE 316 stainless steel with titanium alloy measurement cell
Pressure Media:	All fluids compatible with SAE 316 stainless steel and titanium alloy
Pressure Connection:	Many specialised pressure connection options available to suit individual requirements. Contact the sales team for more information.
Electrical Connection:	Cable outlet or Subsea connector options available
Net. Weight (Kg):	Subject to specification

Version 05-2022

The information provided herein is to the best of our knowledge true and accurate, it is provided for guidance only. All specifications are subject to change without prior notification.

Althen – Your expert partner in Sensors & Controls | althensensors.com

Althen stands for pioneering measurement and custom sensor solutions. In addition we offer services such as calibration, design & engineering, training and renting of measurement equipment.

Germany/Austria/Switzerland
info@althen.de

Benelux
sales@althen.nl

France
info@althensensors.fr

Sweden
info@althensensors.se

USA/Canada
info@althensensors.com

Other countries
info@althensensors.com