

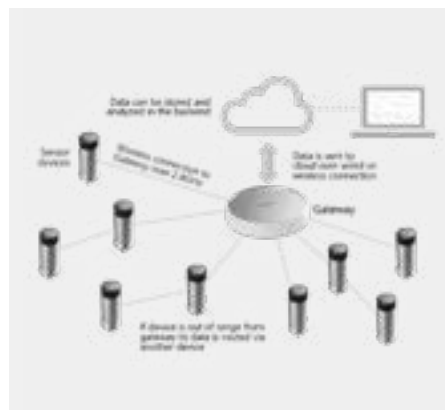

WIRELESS IOT CONDITION MONITORING SOLUTION

Smart Industrial IoT measurement solution for condition monitoring applications.

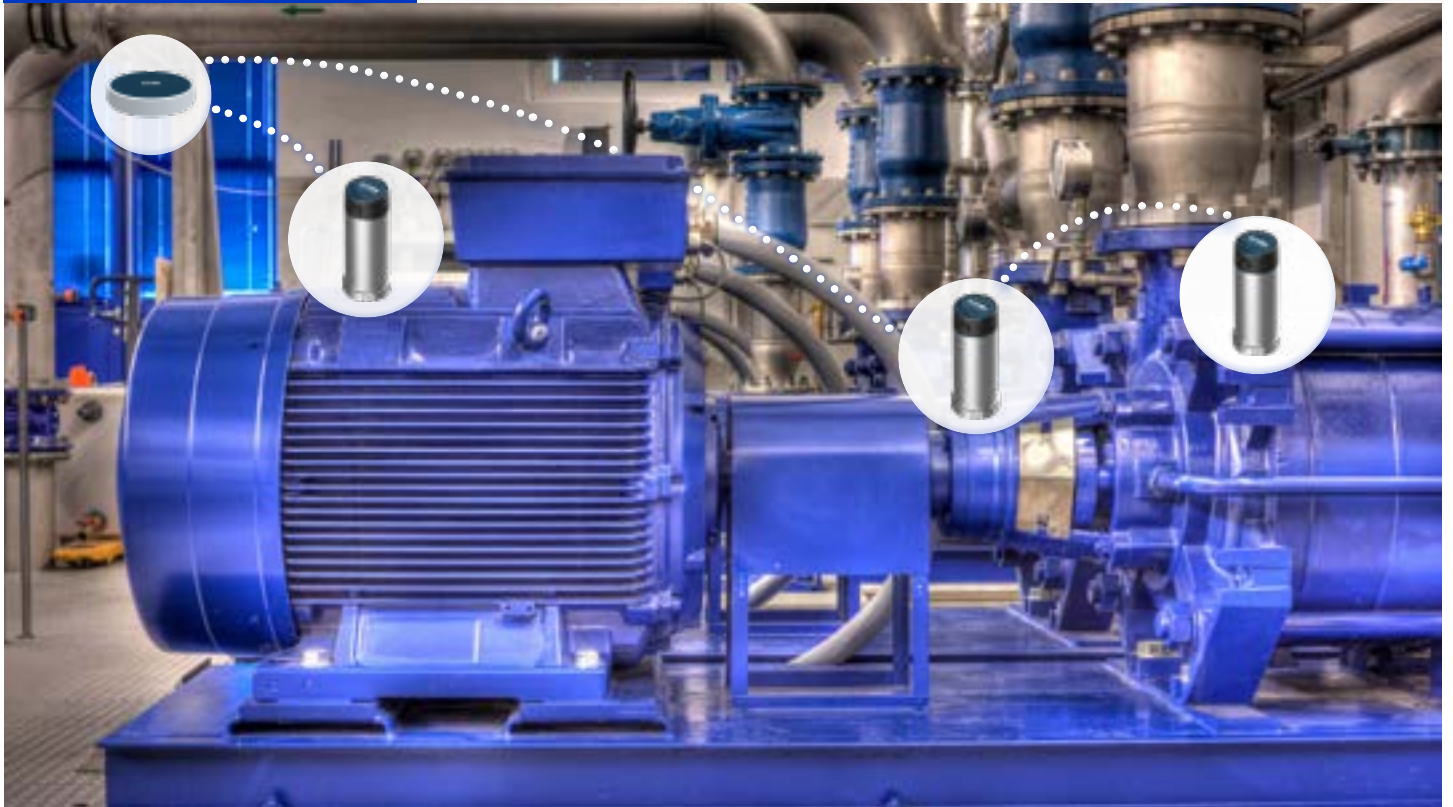

We provide confidence for visionary engineers

CONDITION MONITORING

Condition monitoring is the process of monitoring a particular condition in machinery such as for instance vibration and temperature to identify changes that could indicate a developing fault. It is a major part of predictive maintenance as implementing condition monitoring allows for maintenance to be scheduled and preventive actions taken to prevent damage, future failure and subsequent unplanned downtime of the machinery.

CONDITION MONITORING WITH VIBRATION SENSORS

Condition monitoring with vibration sensors is one of the most innovative ways that businesses and manufacturing companies can save money. Condition monitoring techniques are used on a range of equipment, including rotating machinery, auxiliary systems, and parts such as compressors, pumps, turbines, boilers, motors, conveyors, fans and presses.

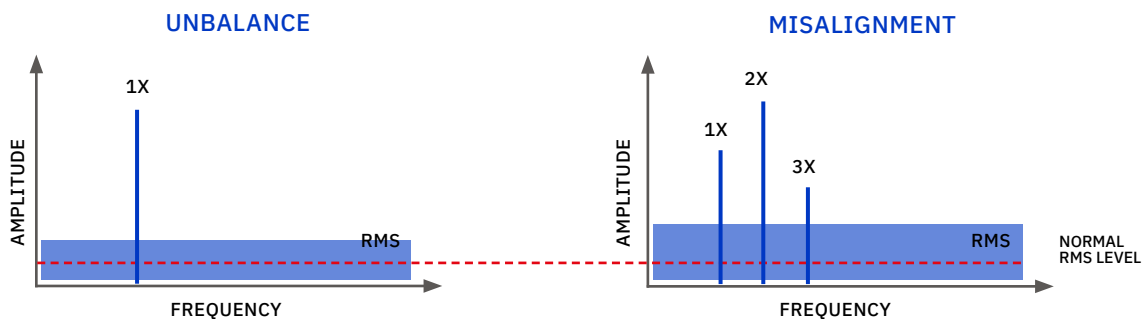
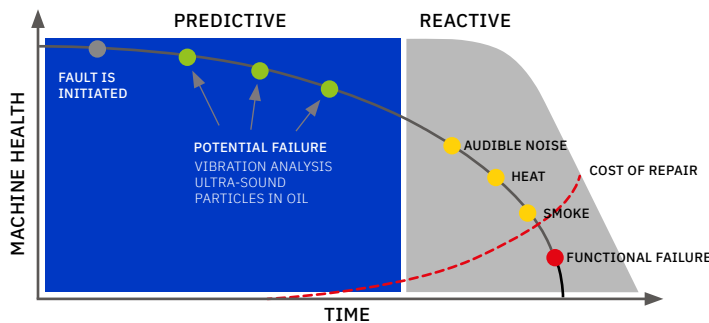

REPAIRS AND REACTIVE MAINTENANCE

Manufacturing companies are majorly dependent on heavy machinery on-site, but also across large distances and sometimes at remote locations. Despite the distance, these machines need to be maintained. Manhours are invested for engineers to stay on-site all the time. Even then the machines will break down over time. Repairs and reactive maintenance must be elaborately planned and carried out in shortest time and at great expense by the engineers.

INCREASE EFFICIENCY WITH PREDICTIVE MAINTENANCE

Management and maintenance of machines are crucial for manufacturing industries. Investments in new advanced machinery are big and depreciation costs are high. Machine faults and operational stoppages cost companies incredible sums of money. The longer the downtime and the bigger the company, the greater the revenue loss and operating cost. To maintain and even improve efficiency predictive maintenance is essential.

INDICATIONS FOR FUTURE MACHINE FAILURE

Abnormal vibrations or high temperatures give early signs of machine failure due to component imbalance, misalignment, wear or improper use of equipment. Those can be now effortlessly identified without manual measurements or expensive wired equipment to increase machine uptime and extend mean time between failures.

VIBRATION AND TEMPERATURE DATA WIRELESSLY SENT TO THE CLOUD

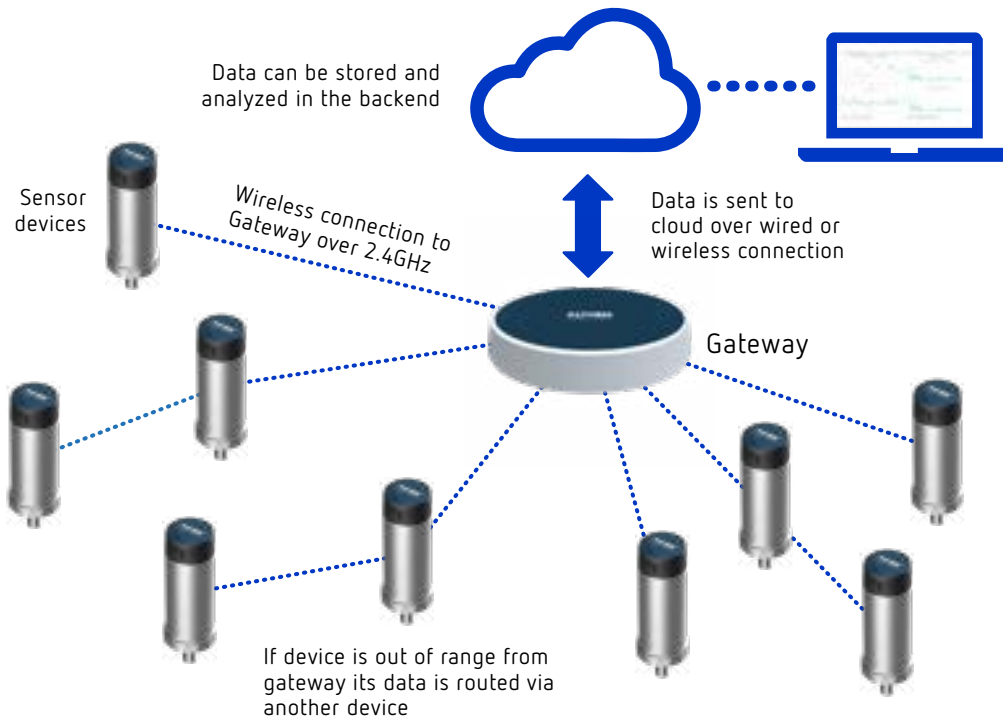

BUILT FOR WIRELESS MESH NETWORK

The wireless IoT monitoring system consists of a network of sensor nodes, which can send their data via an IoT gateway to any computer network or cloud platform.

We offer two different nodes: the industrial sensor nodes measure and monitor tri-axial vibrations and surface temperature of (rotating) equipment, such as pumps, fans, motors, agitators and mixers. The ambient nodes monitor air quality, temperature, humidity, ambient light, noise level and air pressure. For hazardous environments there is an ATEX version (node 6 EX) which also allows predictive maintenance in explosive atmospheres (zone 1).

The wireless battery-operated nodes can be easily and cost-efficiently mounted on existing equipment but can also be part of large-scale mesh networks for collecting sensor data in smart buildings, cities, and factories.

Together with our technology partner Treon we supply a smart industrial IoT measurement solution for condition monitoring applications.

BENEFITS

- **Cost-efficient**
Low installation & maintenance cost, which make this the most cost-efficient solution in the market to monitor every machine in the factory.
- **Scalable**
Tens to many thousands of wireless sensors can work together in an intelligent mesh network to enable condition monitoring at scale.
- **Widely compatible**
Can be integrated with any cloud backend, which makes it extremely convenient to include in a wide range of IIoT solutions.
- **Fully configurable**
Performance indicators such as RMS, PEAK and Kurtosis, along with FFT or high resolution acceleration waveform when needed for analysis with external tools.

ADDITIONAL INFORMATION

- althensensors.com/custom-solutions
- althensensors.com/industries

OVERVIEW OF PRODUCTS



TRI-AXIAL INDUSTRIAL VIBRATION & TEMPERATURES SENSOR NODE

A wireless condition monitoring sensor that is cost-efficient and easy to deploy. It measures tri-axial vibration and surface temperature of rotating equipment, such as pumps, motors, and compressors. Industrial Sensor Node enables identifying abnormal vibrations or high temperatures, which are early signs of machine failure due to component imbalance, misalignment, wear, or improper use of equipment.



TRI-AXIAL INDUSTRIAL VIBRATION & TEMPERATURES SENSOR NODE 6

Industrial Sensor Node 6 measures vibration up to 6kHz, identifying abnormal vibrations, which are early signs of machine failure due to component imbalance, misalignment, wear, or improper use of equipment. Industrial Node 6 provides the needed high resolution data to not only identify emerging issues but also do root-cause analysis.



TRI-AXIAL INDUSTRIAL VIBRATION & TEMPERATURES SENSOR NODE 6 Ex

Industrial Node 6 Ex is a wireless battery-operated condition monitoring device, certified to be safely used in potentially explosive environments (ATEX and IECEx certifications). It measures surface temperature and tri-axial vibration of a rotating equipment, such as pumps, motors, and compressors, with a frequency range up to 6.3kHz.



AMBIENT SENSOR NODE

A compact sensor that measures air quality index, temperature, humidity, ambient light, and barometric pressure. Ambient Sensor Node includes an accelerometer for measuring vibration and movement as well as a HAL-sensor for magnet proximity detection to make it a complete platform to trial or deploy a wide range of IoT-use cases.



INDUSTRIAL IOT GATEWAY

A critical part of any IoT solution. Industrial IoT Gateway collects, processes, and transmits data from sensors to any cloud backend over a wide range of wired and wireless connectivity. It can be freely configured, extended, and run customer edge applications to enable any IoT solution.

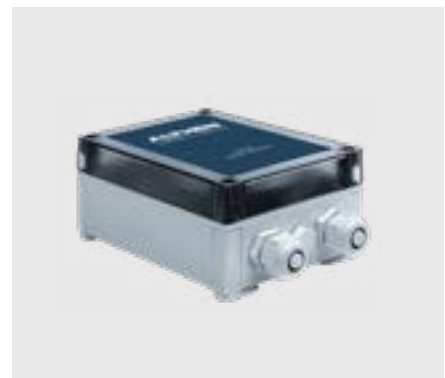

INDUSTRIAL IOT GATEWAY PROTECTIVE ENCLOSURE

Industrial IoT Gateway water and dust-proof enclosure is designed to protect the Industrial IoT Gateway in outdoor or harsh indoor conditions. The enclosure includes a gateway AC/DC power supply and DC cable.

PRODUCT DESCRIPTION

PARTS AND KEYS OF THE NODES

- A. Status light
- B. Orientation notch
- C. Power button
- D. NFC tag
- E. M8 bolt
- F. Nut adapter*
- G. Magnetic epoxy mount adapter*
- H. Glue mount adapter*

* Note that adapters F, G, and H are not included in standard sales box.

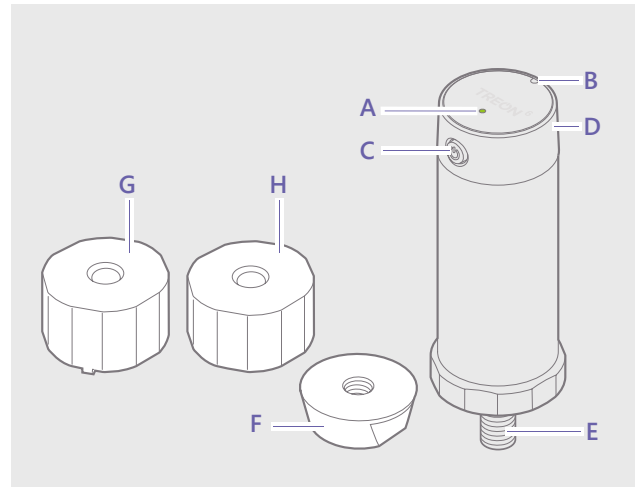

MOUNTING OPTIONS

There are four possible installation methods for the nodes: without adapter, with nut adapter, with magnetic adapter and with glue mount adapter. The best place to mount the sensor depends on the machine and the source of vibration being monitored. Ideally, the contact surface on the machine should be completely flat, smooth, and larger than the base of the sensor.

In case you would also like to measure the temperature of the machine, the optimal installation method is without an adapter. Only with this way the measurement point of the Industrial Node or Industrial Node 6 is deep enough below the machine surface to measure the temperature accurately. For detailed information about the different types of installation, please check the quickstart guide.

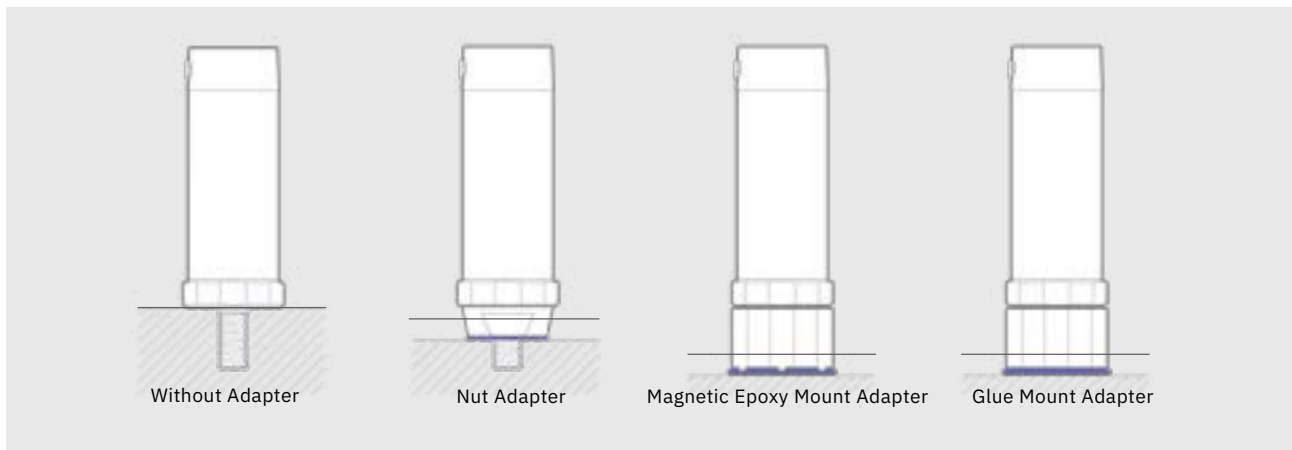

ADDITIONAL INFORMATION MATERIAL

1	Tri-axial industrial vibration & temperatures sensor node	Data sheet / Quickstart Guide
2	Tri-axial industrial vibration & temperatures sensor node 6	Data sheet / Quickstart Guide
3	Tri-axial industrial vibration & temperatures sensor node 6 EX	Data sheet / Quickstart Guide
4	Ambient Sensor Node	Data sheet / Quickstart Guide
5	Industrial IoT Gateway	Data sheet / Quickstart Guide

WIRELESS CONDITION MONITORING IN PRACTICE

The system consists of wireless battery powered industrial sensor nodes and a gateway for communication to transmit data to the cloud. On this page you can find some examples of applications where the sensor system could be of value and improve you operational maintenance.

COST-EFFICIENT WAY TO CAPTURE VIBRATION AND TEMPERATURE DATA ON FULL OPERATIONAL PUMPS.



**Wireless Industrial Iot
Vibration Sensor Node**

Wireless IoT Vibration and Temperature
Measurement Solution

EASY DEPLOYMENT TO EXISTING MACHINERY. FULLY WIRELESS, NO NEED FOR WIRING. PLUG AND PLAY.



Industrial IoT Gateway

For a wired or wireless connection
of sensor nodes to backends

INDUSTRIAL ATEX NODE DESIGNED FOR DEMANDING CONDITIONS SUCH AS EXPLOSION PROOF ENVIRONMENTS.



**Wireless Industrial Iot
Vibration Sensor Node 6 EX**

Wireless IoT Vibration and Temperature
Measurement Solution

NINE PRE-CALCULATED VIBRATION KEY PARAMETERS FOR MONITORING MOVING BELTS IN FACTORY PROCESSES.



**Wireless Industrial Iot
Vibration Sensor Node 6**

Wireless IoT Vibration and Temperature
Measurement Solution

PREVENT DOWNTIME AND IMPROVE EFFICIENCY OF VENTILATION AND AIR INSTALLATIONS.



**Wireless Industrial Iot
Vibration Sensor Node 6**

Wireless IoT Vibration and Temperature
Measurement Solution

COST-EFFICIENT, SCALABLE, AND EASY IMPLEMENTABLE SENSORS FOR PAPER PRODUCTION MACHINES.



Wireless Ambient Sensor Node

Environmental quality from
offices to data centers

WATER & DUST PROOF PROTECTIVE ENCLOSURE. PRACTICAL FOR INDUSTRIAL USE AND DEMANDING ENVIRONMENTS.



**Industrial IoT Gateway
Protective Disclosure**

When surrounding are harsh

DASHBOARDING & ANALYTICS

Our user-friendly data analytic and machine learning solutions assist in keeping you on top of things and your business running smoothly.



DASHBOARD FEATURES

RICH DATA VISUALIZATION

- A great choice of widgets for different visualizations
- Clear (and fast) overviews for subjects and events
- Powerful filter and aggregation options

POWERFUL ANALYTICS

Easy-to-use data explorer to uncover new patterns

Drill-down on events to more granular levels

Give everyone in the company a tool to explore and analyze the data

TO MEET YOUR MEASUREMENT NEEDS

ON	3	8	15	1	6	ON
DEMAND MEASUREMENT	TIMED INTERVALS	MEASUREMENT SETTINGS	CALCULATION SETTINGS	1 HOUR INTERVAL	AT 6 HOUR INTERVAL	WITH ON DEMAND
Measurement executed immediately on command	Configurable timers to execute measurements	Pre-configured sets of measurement parameters	Pre-configured sets of calculation parameters	KEY TREND VALUES	LOW RANGE FFT	RAW DATA SAMPLES
Can trigger up to 8 different measurements	Can trigger up to 8 different measurements	<ul style="list-style-type: none"> ▪ G-range ▪ Axis ▪ Sample amount ▪ Select calculations Measurement setting can be associated with time interval/s or on-demand measurement	<ul style="list-style-type: none"> ▪ What is calculated ▪ Filters ▪ FFT parameters Calculation setting can be associated with one or more measurements	<ul style="list-style-type: none"> ▪ Triaxial v-RMS, PEAK, P2P ▪ 10-1000Hz ▪ a-RMS, PEAK, P2P ▪ CREST, KURTOSIS ▪ 10-1000Hz ▪ From 34134 samples 	<ul style="list-style-type: none"> ▪ Triaxial Fmax 2604Hz ▪ Averages 3 ▪ Overlap 40% ▪ Hanning window ▪ From 4096 samples ▪ LOR 1600 / Bin 1.6Hz ▪ From 36045 samples 	<ul style="list-style-type: none"> ▪ Triaxial, 34134 samples ▪ 1.28s sampling time and/or ▪ Vertical, 68268 samples ▪ 2.56s sampling time

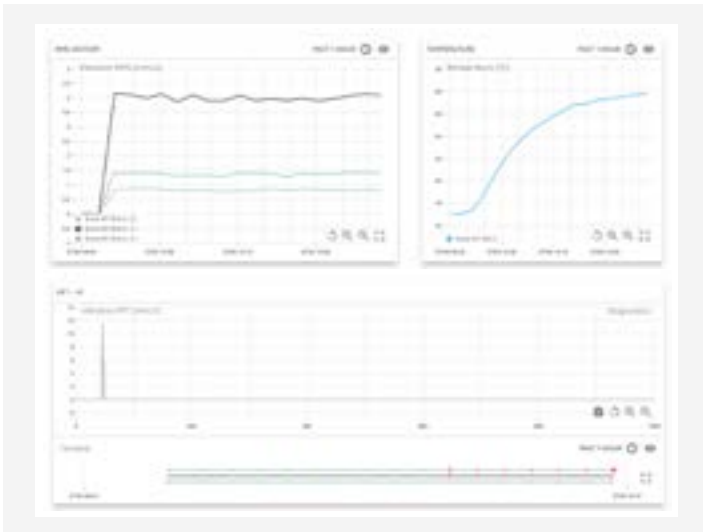

ALTHEN MONITOR

Threshold triggers and DIN ISO standards.

ISO-10816 STANDARD

The ISO-10816 standard provides a general guide for the assessment of measured radial vibrations on the bearing housings of industrial machinery. Although the factors listed are not always the only ones that need to be considered when identifying faults, the standard is very useful for carrying out basic vibration analysis.

The criteria specified in ISO-10816 apply to machinery sets with an output of more than 15 kW and operating speeds between 120 min⁻¹ and 15 000 min⁻¹. They include steam turbines, generators, turbo compressors, industrial gas turbines, electric motors of all types, blowers, and fans. These are specified in more detail in Annexes 1 to 9 of the standard.

Of course, there are machines with power requirements or speeds that do not fall within the scope of the standard; however, most machines can be assessed according to these guidelines. The IoT Monitor also allows the measuring of individual machine data if the standard data cannot be used.

The aim of the standard is to classify the machine condition into four different classes based on vibration data for acceptance measurements and operational monitoring:

- **Zone A:** The vibrations are as low as they usually occur with machines in new condition.
- **Zone B:** The vibrations are low enough for the machine to run continuously.
- **Zone C:** The vibrations are so high that the machine can still run for a limited time. Corrective action should be taken at the next shutdown opportunity.
- **Zone D:** The vibrations are so high that continued operation is dangerous and damage to the machine may occur.

Some machines can be rigidly or elastically coupled together or connected by gears. The axis of rotating shafts can be horizontal, vertical, or inclined at any angle. The following table, in combination with other parameters, can be used to assess the vibration severity of your machines in accordance with ISO-10816.

ISO 10816	
Vibration mm ` s	CLASS 1
0,71	GOOD
1,80	SATISFACTORY
5,50	UNSATISFACTORY
7,10	UNAPCEPTABIE

ALTHEN MONITOR

Threshold triggers and DIN ISO standards.

Vibration data can be used relatively easily with the measurement data collected from your machines in combination with the example table shown above. Both predefined and customized values can be defined as threshold **triggers in the IoT Monitor**.

Two different levels can be defined for these: Warning and Alarm. As soon as a predefined value is exceeded, an alarm can be triggered (e.g. by email). This allows problematic machines to be identified quickly and targeted maintenance measures to be carried out before serious damage occurs.

ISO 10816	
Alert level preset	ISO-10816 Group 1 (rigid)
	ISO-10816 Group 1 (flexible)
Alert level	ISO-10816 Group 2 (rigid)
	ISO-10816 Group 2 (flexible)
	ISO-10816 Group 3 (rigid)
	ISO-10816 Group 3 (flexible)
	ISO-10816 Group 4 (rigid)
	ISO-10816 Group 4 (flexible)

EVALUATION OF MACHINE VIBRATIONS THROUGH MEASUREMENTS ON NON-ROTATING PARTS

10 - 1000Hz / > 600 min ⁻¹ (2 - 1000Hz / > 1200 min ⁻¹)	Vibration velocity									
		11.00	Red		Yellow		Red		Yellow	
		7.10	Red		Yellow		Green		Yellow	
		4.50	Yellow		Green		Yellow		Green	
		3.50	Yellow		Green		Blue		Green	
		2.80	Green		Green		Blue		Green	
		1.40	Green		Blue		Blue		Blue	
		0.71	Blue		Blue		Blue		Blue	
mm/s ms										
Setting	Strong		Soft		Strong		Soft			
Machine type	Pumps > 15 KW / radial, axial, diagonal				Medium size machines 15KW < P < 300KW		Great machines 300KW < P < 50 MW			
	Standard traction		Intermediate shaft / belt drive		Engines 160 mm < H < 315 mm		Engines 315 mm < H			
Group	Group 4		Group 3		Group 2		Group 1			



New machine condition

Unlimited long-term operation allowable







Short-term operation allowable

Vibration causes damage

OUR BUILDING BLOCKS

Our sensor categories.

A sensor measures a physical quantity. The variables are located in the following areas: pressure, force, inclination, displacement, acceleration, temperature, strain, vibration or any one of a great number of other environmental phenomena. Sensors convert the measured quantity into a standardized control signal that is converted to a human-readable display at the sensor location or transmitted electronically over a network for reading or further processing.

bar	PRESSURE	g	ACCELERATION
N	FORCE	m/s²	VIBRATION
Nm	TORQUE	°/s	ANGULAR RATE
ε	STRAIN	°C	TEMPERATURE
kg	WEIGHT		SIGNAL CONDITIONING
mm	DISPLACEMENT		DATALOGGERS
α	ROTATION		AUTOMATION
	JOYSTICK	A	TURN-KEY SYSTEMS
	INCLINATION		

 Sweden | Norway | Denmark | Finland

 Netherlands | Belgium | Luxembourg

 USA | Canada

 Germany | Switzerland | Austria

 France

ALTHEN SENSORS & CONTROLS OFFICES

■ Netherlands | Belgium | Luxembourg

ALTHEN Industrial IoT B.V.
Verrijn Stuartlaan 40
2288 EL Rijswijk
Netherlands
Phone: +31 70 3 92 44 21
Email: sales@althen.nl

■ Germany | Switzerland | Austria

ALTHEN GmbH Mess- und Sensortechnik
Dieselstraße 2
65779 Kelkheim
Germany
Phone: +49 6195 7 00 60
Email: info@althen.de

■ France

ALTHEN / MIDIF
26, avenue de la Méditerranée
34110 Frontignan
France
Phone: +33 4 67 78 61 66
Email: info@althensensors.fr

■ USA | Canada

ALTHEN Sensors & Controls Inc
2340 Littler Lane
Oceanside CA 92056
USA
Phone: +1 858 6 33 35 72
Email: info@althensensors.com

■ Sweden | Norway | Denmark | Finland

ALTHEN Sensors & Controls AB
Stora torget 6C
76130 Norrtälje
Sweden
Phone: +46 8 7 95 24 90
E-Mail: info@althensensors.se

DE-01-2024-02



Further information can be found at
www.althensensors.com/de/loesungen/iiot-zustandsueberwachung/
www.althensensors.com/de/